

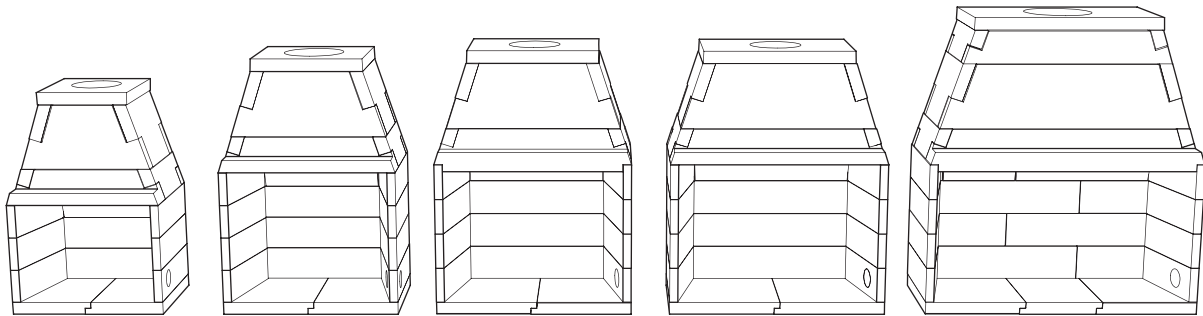

WWW.BURNTECH.COM



Modular Masonry Fireplace Installation Instructions Models TFS/OFS* 33 /39 /44 /49 /63

THIS ENTIRE INSTALLATION GUIDE IS TO BE FOLLOWED IN ITS ENTIRETY FOR INDOOR TRADITIONAL FIREPLACE SERIES (TFS MODELS) INSTALLATIONS. * ITEMS DESIGNATED WITH **(OFS)** SHOULD BE CROSS REFERENCED WITH THE SUPPLEMENTAL OUTDOOR FIREPLACE INSTALLATION GUIDE WHEN INSTALLING OUTDOOR FIREPLACES (OFS MODELS). PLEASE REFER TO THE SUPPLEMENTAL OUTDOOR FIREPLACE INSTALLATION GUIDE FOR IMPORTANT INFORMATION SPECIFIC TO OUTDOOR FIREPLACE INSTALLATIONS.

READ THIS INSTALLATION MANUAL IN ITS ENTIRETY FOR COMPLETE INSTALLATION INSTRUCTIONS AND IMPORTANT WARNING NOTICES AS THEY APPLY TO ALL Burntech® FIREPLACE INSTALLATIONS.

IF YOU DID NOT RECEIVE A COPY OF THE SUPPLEMENTAL INSTALLATION GUIDE, ONE CAN BE DOWNLOADED OR SENT TO YOU FREE OF CHARGE. PLEASE VISIT OUR WEBSITE WWW.BURNTECH.COM OR CALL US AT (818)564-4253.

THIS WOOD-BURNING FIREPLACE COMPLIES WITH UL127 STANDARD AS A FACTORY-BUILT APPLIANCE.

▲WARNING: THIS FIREPLACE IS APPROVED FOR USE AS A WOOD BURNING FIREPLACE. IT HAS NOT BEEN TESTED OR APPROVED FOR UNVENTED GAS LOGS.

▲WARNING: IMPROPER INSTALLATION, ADJUSTMENT, ALTERATION, SERVICE OR MAINTENANCE CAN CAUSE INJURY, PROPERTY DAMAGE OR LOSS OF LIFE. REFER TO THIS MANUAL FOR ASSISTANCE OR ADDITIONAL INFORMATION. CONSULT A QUALIFIED INSTALLER OR LOCAL DISTRIBUTOR.

SAVE THIS BOOK

This book is valuable. In addition to instructing you on how to install and maintain your appliance, it also contains information that will enable you to obtain replacement parts or accessory items when needed. Keep with your other important papers.



Report No. 08-154

Do not store gasoline or other flammable vapors and liquids in the vicinity of this or any other appliance.



ICC Evaluation Services
Report No. 2401



rev 8-22-2013

This page has been left intentionally blank.

CONTENTS

TFS-33 Fireplace Parts Diagrams	Pg. 2, 3
TFS-39/44/49 Fireplace Parts Diagrams	Pg. 4, 5
TFS-63 Fireplace Parts Diagrams	Pg. 6, 7
Fireplace Overall Dimensions: TFS-33	Pg. 8
Fireplace Overall Dimensions: TFS-39/44/49	Pg. 9
Fireplace Overall Dimensions: TFS-63	Pg. 10
Fireplace Framing Dimensions	Pg. 11 ~ 13
Safety Information	Pg. 14
Product Overview	Pg. 15
Clearances to Combustibles	Pg. 16
Combustible Floor Clearances	Pg. 16
Burntech®® Fireplace & Chimney System	Pg. 16
Chimney System Heights	Pg. 16
Supporting Floor Systems	Pg. 17, 18
Combustible Floor Installations	Pg. 19
What You Will Need	Pg. 20
Fireplace Assemblies	Pg. 21~26
Installing Damper and Chimney System	Pg. 27
Firestop Radiation Shield	Pg. 28
Burntech® Firebrick Liners	Pg. 28
Fireplace Finishes and Combustible Trim Clearances	Pg. 29
Installing Outside Air	Pg. 29
Adding a Gas Pipe	Pg. 30
Adding Electrical Connection	Pg. 30
Fireplace Door Accessory	Pg. 30
Burntech® Owner's Operation & Precautions	Pg. 30
Starting A Fire and Basic Operation	Pg. 31
Annual Fireplace Maintenance	Pg. 31
Customer Service & Parts Replacement	Pg. 31
Appendix I	Pg. 32
Appendix II	Pg. 33
Limited Warranty	Pg. 33

Below is a sample picture of the rating plate that is located inside the lower dome side of your fireplace. Model Number, Date of Manufacture and Serial Number should be stamped on the plate where indicated.

 BURNTech FIREPLACE SOLUTIONS 6520 Platt Ave. #577 West Hills, CA 91307	DO NOT REMOVE THIS LABEL See Burntech installation and operating instructions for this model. Contact local building officials about restrictions and installation specifications in your area.	 Report No. 08-154  ICC Evaluation Services Report No. 2401																										
DATE OF MFG. <input style="width: 100px;" type="text"/> SERIAL No. <input style="width: 100px;" type="text"/>																												
MODEL No.: <input style="width: 80px;" type="text"/> TFS33-12 <input style="width: 80px;" type="text"/> TFS39-XX <input style="width: 80px;" type="text"/> TFS44-XX <input style="width: 80px;" type="text"/> TFS49 <input style="width: 80px;" type="text"/> TFS63																												
<p>⚠ WARNING: THIS FIREPLACE HAS BEEN TESTED FOR USE ONLY WITH APPROVED GLASS DOORS. TO REDUCE THE RISK OF FIRE OR INJURY, CONSULT OWNER'S MANUAL.</p> <p>THIS FIREPLACE IS DESIGNED FOR USE ONLY WITH SOLID WOOD LOGS, PLUMBED LPG OR NG LOG LIGHTERS OR PLUMBED ANSI Z21.60 DECORATIVE GAS LOGS. Consult instructions included with this firebox for further information.</p>	<p>⚠ WARNING: Use only approved, listed Chimney Pipe as follows: TFS33 /39-12 /44-12: UL103-12"-Class A (DM12-12", FMI 12" chimneys). TFS49: UL103-14"-Class A Please refer to pipe manufacturer's installation instructions.</p> <p>Chimney Height: Max.: 40 ft. Min.: 14 ft. (17 ft. with 1 or 2 offset sections maximum)</p>	<p>FIREPLACE CLEARANCES TO COMBUSTIBLES:</p> <table border="0"> <tr><td>UNIT FRONT, SIDES, REAR</td><td>2" (51 mm)</td></tr> <tr><td>COMBUSTIBLE FLOOR (TFS33/39/44/49)</td><td>6" (152 mm)</td></tr> <tr><td>COMBUSTIBLE FLOOR (TFS63 ONLY)</td><td>8" (203 mm)</td></tr> <tr><td>COMBUSTIBLE SHEATHING ABOVE OPENING TOP</td><td>18" (457 mm)</td></tr> <tr><td>SHEATHING OR TRIM TO OPENING SIDES</td><td>8" (203 mm)</td></tr> <tr><td>MANTLE ABOVE OPENING</td><td>12" (305 mm)</td></tr> <tr><td>OPENING TO SIDE WALL</td><td>24" (610 mm)</td></tr> <tr><td>HEARTH EXTENSION BEYOND FRONT</td><td>20" (508 mm)</td></tr> <tr><td>HEARTH EXTENSION BEYOND SIDES</td><td>12" (305 mm)</td></tr> <tr><td>INSULATION FROM FIREBOX</td><td>2" (51 mm)</td></tr> </table> <table border="0"> <tr> <td>MANTEL CLEARANCES</td> <td>MANTEL ABOVE OPENING:</td> </tr> <tr> <td>0" - 3" : 1-1/2" MAX. PROJ.</td> <td>MIN. - 3" SHEATHING OR TRIM TO OPENING SIDES 8"</td> </tr> <tr> <td>3" - 12" : 1-1/2" - 8" MAX. PROJ.</td> <td></td> </tr> </table>	UNIT FRONT, SIDES, REAR	2" (51 mm)	COMBUSTIBLE FLOOR (TFS33/39/44/49)	6" (152 mm)	COMBUSTIBLE FLOOR (TFS63 ONLY)	8" (203 mm)	COMBUSTIBLE SHEATHING ABOVE OPENING TOP	18" (457 mm)	SHEATHING OR TRIM TO OPENING SIDES	8" (203 mm)	MANTLE ABOVE OPENING	12" (305 mm)	OPENING TO SIDE WALL	24" (610 mm)	HEARTH EXTENSION BEYOND FRONT	20" (508 mm)	HEARTH EXTENSION BEYOND SIDES	12" (305 mm)	INSULATION FROM FIREBOX	2" (51 mm)	MANTEL CLEARANCES	MANTEL ABOVE OPENING:	0" - 3" : 1-1/2" MAX. PROJ.	MIN. - 3" SHEATHING OR TRIM TO OPENING SIDES 8"	3" - 12" : 1-1/2" - 8" MAX. PROJ.	
UNIT FRONT, SIDES, REAR	2" (51 mm)																											
COMBUSTIBLE FLOOR (TFS33/39/44/49)	6" (152 mm)																											
COMBUSTIBLE FLOOR (TFS63 ONLY)	8" (203 mm)																											
COMBUSTIBLE SHEATHING ABOVE OPENING TOP	18" (457 mm)																											
SHEATHING OR TRIM TO OPENING SIDES	8" (203 mm)																											
MANTLE ABOVE OPENING	12" (305 mm)																											
OPENING TO SIDE WALL	24" (610 mm)																											
HEARTH EXTENSION BEYOND FRONT	20" (508 mm)																											
HEARTH EXTENSION BEYOND SIDES	12" (305 mm)																											
INSULATION FROM FIREBOX	2" (51 mm)																											
MANTEL CLEARANCES	MANTEL ABOVE OPENING:																											
0" - 3" : 1-1/2" MAX. PROJ.	MIN. - 3" SHEATHING OR TRIM TO OPENING SIDES 8"																											
3" - 12" : 1-1/2" - 8" MAX. PROJ.																												
THIS APPLIANCE NEEDS FRESH AIR FOR SAFE OPERATION AND MUST BE INSTALLED SO THERE ARE PROVISIONS FOR ADEQUATE COMBUSTION AND VENTILATION AIR.																												
LISTED MASONRY FIREPLACE SYSTEM COMPLIES WITH APPLICABLE REQUIREMENTS OF UL127																												
Fireplace is designed for installation per the National Fire Protection Association Standard for Chimneys, Fireplaces, Vents and Solid Fuel-Burning Appliances (NFPA 211).																												
<p>⚠ WARNING: THIS FIREPLACE HAS NOT BEEN TESTED WITH AN UNVENTED GAS LOG SET. TO REDUCE THE RISK OF FIRE OR INJURY, DO NOT INSTALL AN UNVENTED GAS LOG SET INTO FIREPLACE.</p>																												

TFS-33 Fireplace Parts Diagrams

Combustible Floor Systems

Non-Combustible Floor Systems

Figure 1

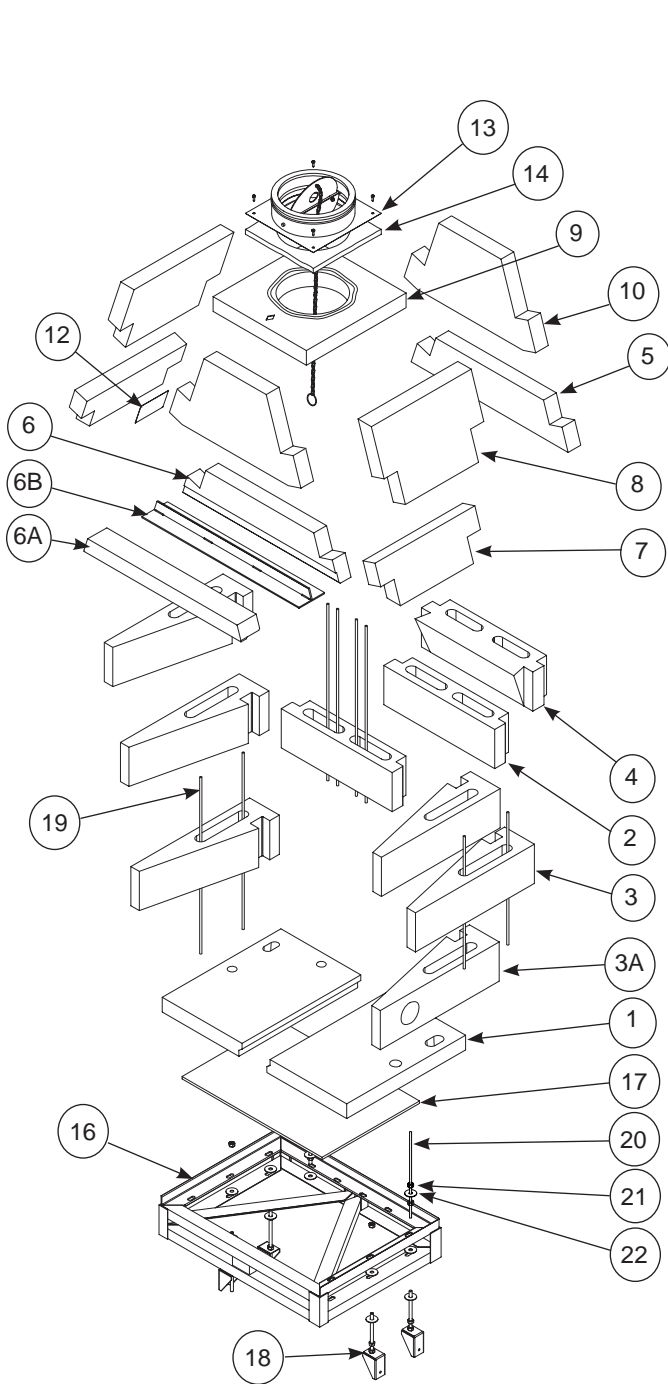
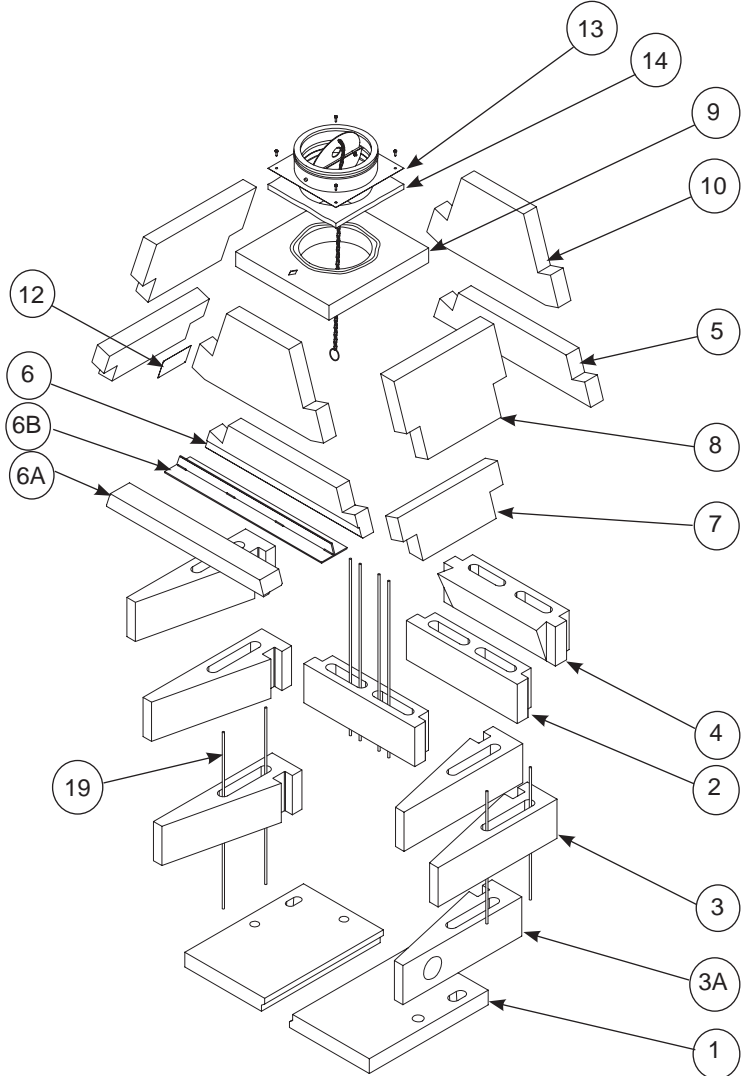

Figure 2



See Page 17 thru 19 for combustible floor and framing anchoring illustrations.

TFS-33 Fireplace Parts List

ITEM	P/N	DESCRIPTION	QTY
1	TFS33-1	HEARTH (Left or Right)	2
2	TFS33-2	REAR WALL	2
3	TFS33-3	SIDE WALL	5
3A	TFS33-3A	SIDE WALL (with Ø4" Outside Combustion Air Hole)	1
4	TFS33-4	DNDRFT DIVERTER	1
5	TFS33-5	DOME REAR - LOWER	1
6	TFS33-6	LINTEL	1
6A	TFS33-6A	LINTEL FRONT	1
6B	TFS33-6B	T-BAR	1
7	TFS33-7	DOME SIDE - LOWER	2
8	TFS33-8	DOME SIDE - MIDDLE	2
9	TFS33-9	DOME TOP FOR 12" CLASS A CHIMNEY	1
10	TFS33-10	DOME FRONT/REAR - MIDDLE	2
12	TFS521	RATING PLATE, TFS33	1
13	AP-AC12 *	Ø12" DAMPER / ANCHOR PLT	---
14	BAP-IG *	INSULATION BLANKET	---
15	BFP4-AK *	4 INCH DIA. OUTSIDE AIR KIT	1
16	BK33 *	STEEL SUPPORT PLATFORM 6 INCH HIGH, TFS33	1
17	NOT SUPPLIED	CEMENT BOARD	---
18	SBK-AB8 *	ASSY, FLOOR JOIST BRACE	4
19	<i>included</i>	#4 REBAR (Ø1/2") x 28"	8
20	NOT SUPPLIED	ALL-THREAD BAR, 1/2-13 UNC X 12"	4
21	NOT SUPPLIED	NUT, 1/2-13 UNC	8
22	NOT SUPPLIED	WASHER, Ø1/2" X 1/16	8

* ITEMS NOTED ARE SOLD SEPARATELY

ITEMS INDICATED AS "NOT SUPPLIED" CAN BE OBTAINED FROM YOUR LOCAL HARDWARE STORE.

**Optional Outside Ø4"
Combustion Air Kit
Model No.: BFP4-AK**

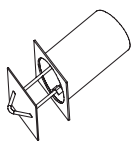

(Ø4" Ducting not included)



**FBK33SHB- Herringbone
FBK33FRB- Running Bond**

Refractory Firebrick Liners
(Herringbone Pattern shown, also available
in Running Bond - see Pg.28)

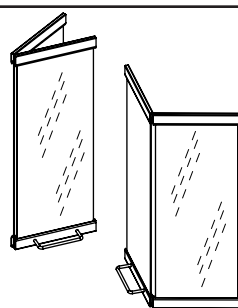

**Only the following
doors have been tested
and approved for use
with this fireplace:**
Crown-Breckinridge
or
McKenzie-Pendelton

Combustible Floor Systems

Non-Combustible Floor Systems

Figure 5

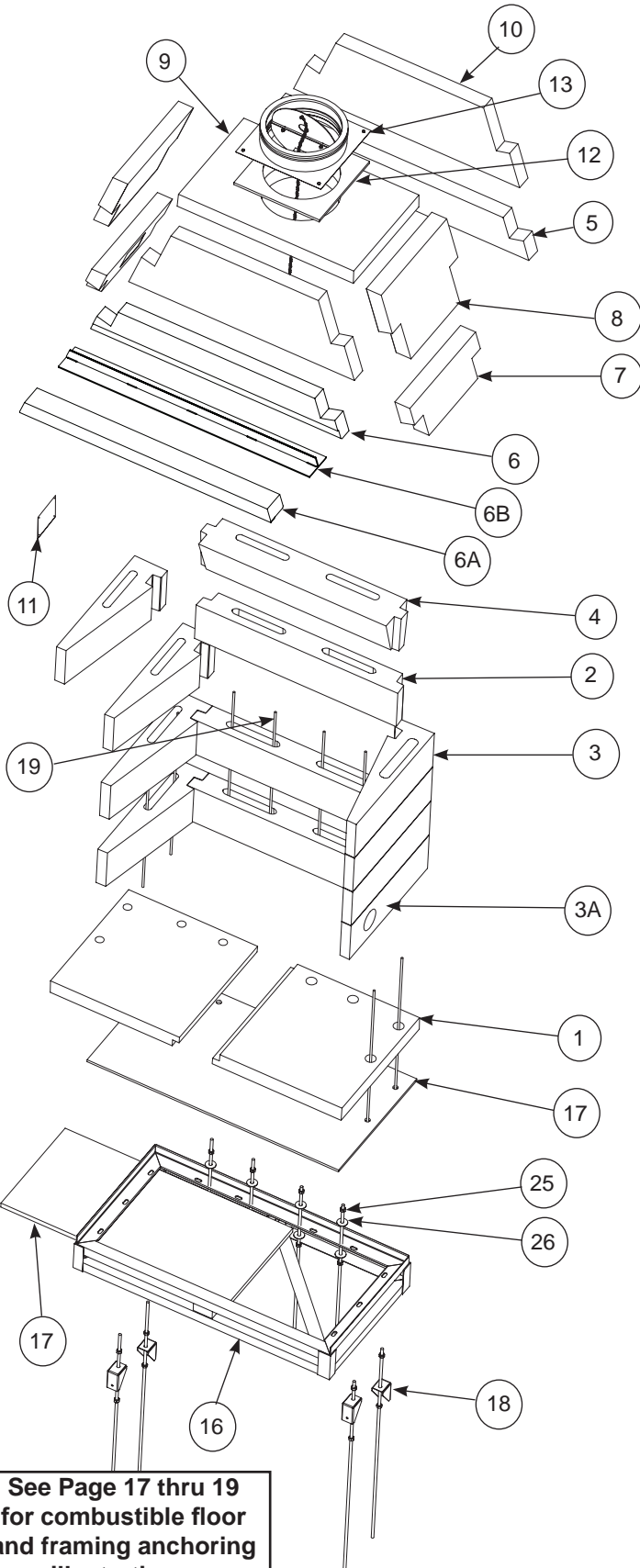

See Page 17 thru 19
for combustible floor
and framing anchoring
illustrations.

Figure 6

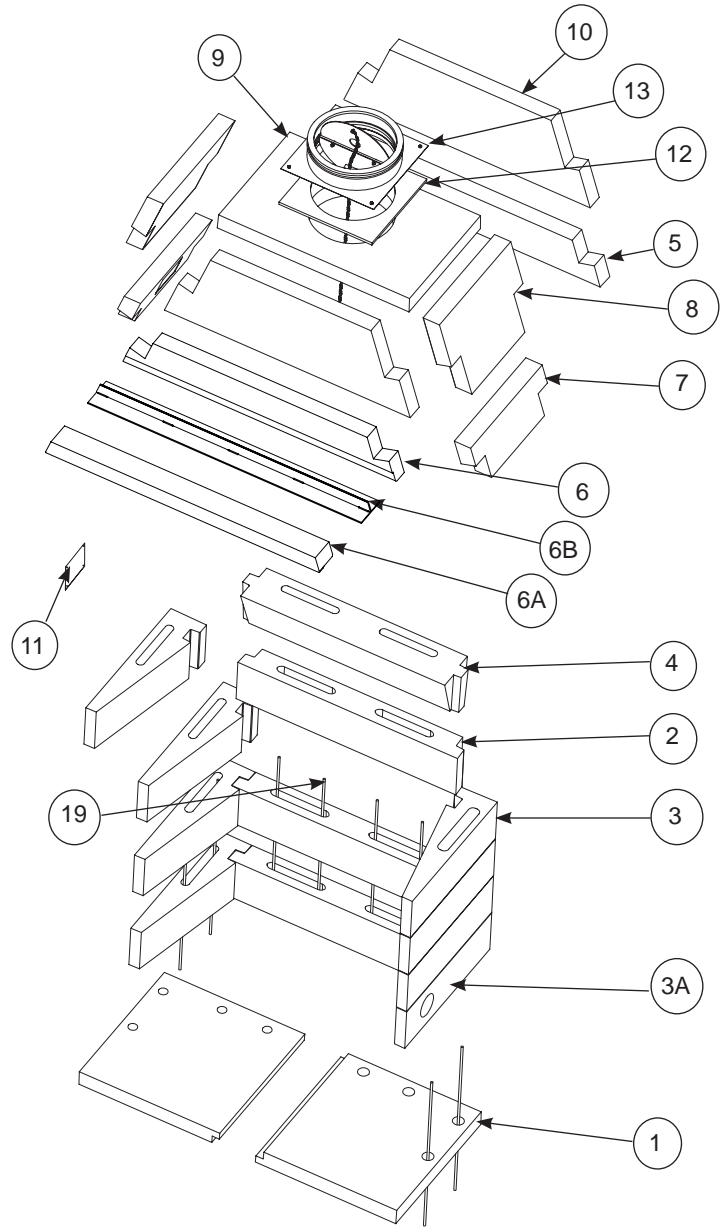

TFS-39/44/49 Fireplace Parts List

ITEM	P/N	DESCRIPTION	QTY
1	TFS39-1 TFS44-1 TFS49-1	HEARTH (Left or Right)	2
2	TFS39-2 TFS44-2 TFS49-2	REAR WALL	2
3	TFS39-3 TFS44-3 TFS49-3	SIDE WALL	5
3A	TFS39-3A TFS44-3A TFS49-3A	SIDE WALL (with Ø4" Outside Combustion Air Hole)	1
4	TFS39-4 TFS44-4 TFS49-4	SMOKE SHELF (Downdraft Diverter)	1
5	TFS39-5 TFS44-5 TFS49-5	DOME REAR - LOWER	1
6	TFS39-6 TFS44-6 TFS49-6	LINTEL	1
6A	TFS39-6A TFS44-6A TFS49-6A	LINTEL FRONT	1
6B	TFS39-6B TFS44-6B TFS49-6B	T-BAR	1
7	TFS39-7 TFS44-7 TFS49-7	DOME SIDE - LOWER	2
8	TFS39-8 TFS44-8 TFS49-8	DOME SIDE - UPPER	2
9	TFS39-9 TFS44-9 TFS49-9	DOME TOP Ø12" DOME TOP Ø12" DOME TOP Ø14"	1
10	TFS39-10 TFS44-10 TFS49-10	DOME FRONT/REAR - MIDDLE	2

ITEM	P/N	DESCRIPTION	QTY
11	TFS521	RATING PLATE	1
12	BAP-IG	1" FIBERGLASS INSULATION BLANKET	1
13	APD-AC12 or APD-AC14	DAMPER / ANCHOR PLATE (Ø12 OR Ø14)	1
14	BFP4-AK *	4 INCH DIA. OUTSIDE AIR KIT	1
16	BK39 * BK44 * BK49 *	6" METAL BASE	1
17	NOT SUPPLIED	CEMENT BOARDS	2
18	SBK-AB8 *	ASSY, FLOOR JOIST BRACE	4
19	<i>INCLUDED</i>	#4 REBAR (Ø1/2") x 28"	8
20	NOT SUPPLIED	ALL-THREAD BAR, 1/2-13 UNC X 12"	4
21	NOT SUPPLIED	NUT, 1/2-13 UNC	8
22	NOT SUPPLIED	WASHER, Ø1/2" X 1/16	8

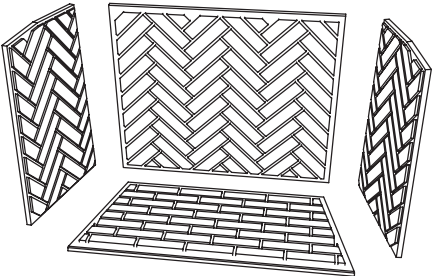

TFS(33,39,44,49) FBK--SHB- Herringbone
TFS(33,39,44,49) FBK--FRB- Running Bond

Refractory Firebrick Liners
(Herringbone Pattern shown, also available in Running Bond - see Pg.28)

* ITEMS NOTED ARE SOLD SEPARATELY.

ITEMS INDICATED AS "NOT SUPPLIED" CAN BE OBTAINED FROM YOUR LOCAL HARDWARE STORE.

Optional Outside Ø4" Combustion Air Kit
Model No.: BFP4-AK

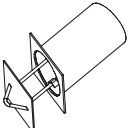

(Ø4" Ducting not included)

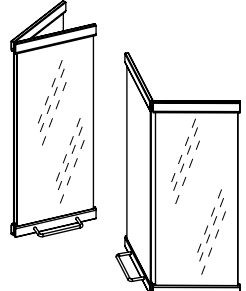

Only the following doors have been tested and approved for use with this fireplace:
Crown-Breckinridge
or
McKenzie-Pendelton

TFS-63 Fireplace Parts Diagrams

Combustible Floor Systems

Figure 4

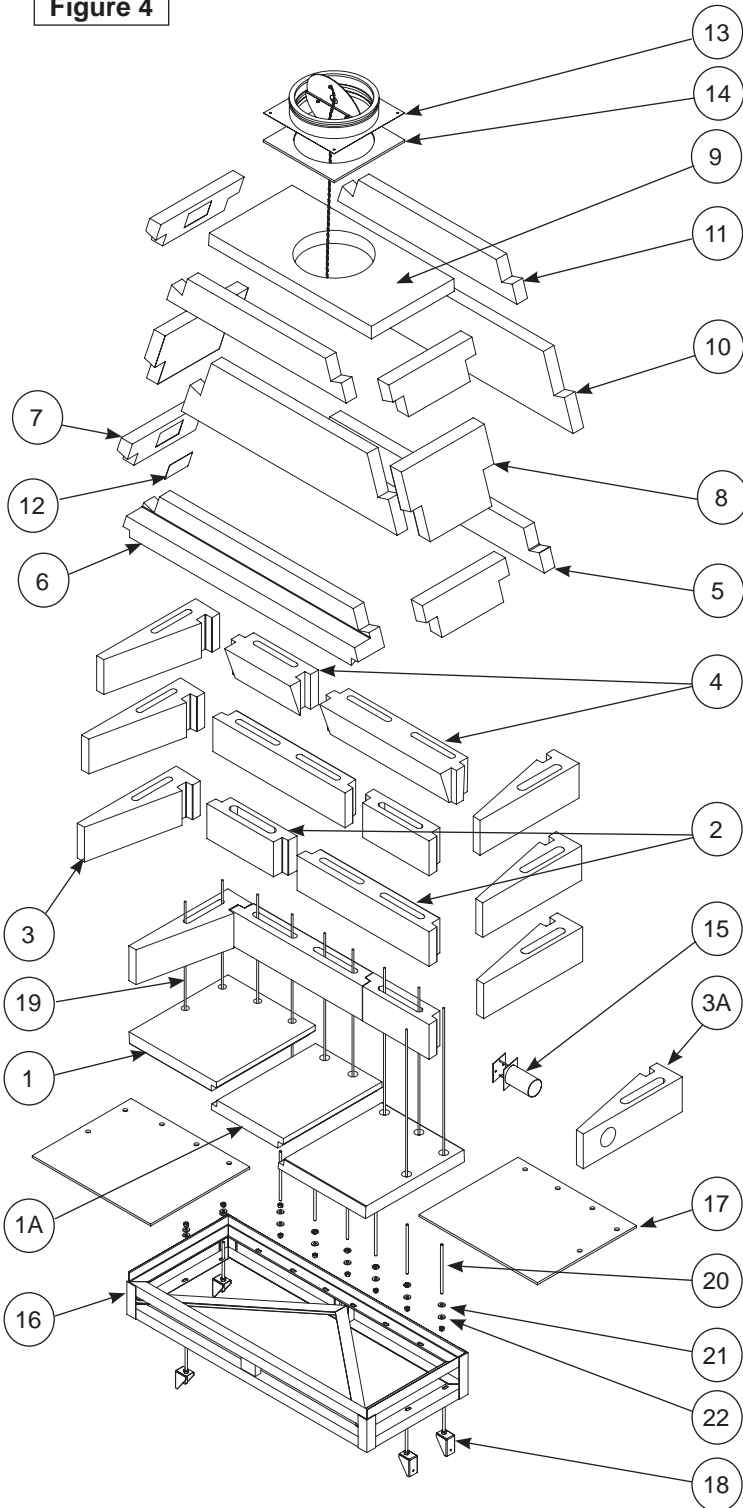

Non-Combustible Floor Systems

Figure 5

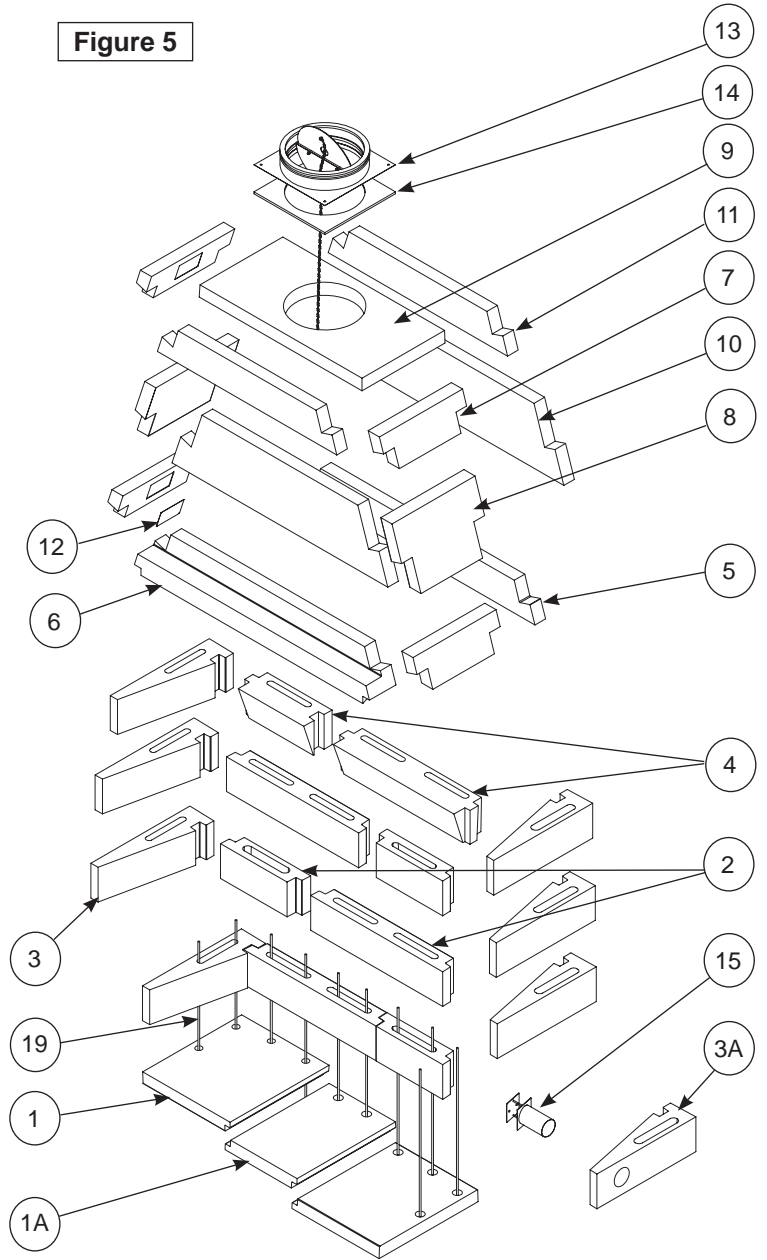

See Page 17 thru 19 for combustible floor and framing anchoring illustrations.

TFS-63 Fireplace Parts List

ITEM	P/N	DESCRIPTION	QTY
1	TFS63-1	HEARTH (Left or Right)	2
1A	TFS63-1A	HEARTH CENTER	1
2	TFS63-2	REAR WALL (2 PIECES)	3 sets
3	TFS63-3	SIDE WALL	7
3A	TFS63-3A	SIDE WALL (with Ø4" Outside Combustion Air Hole)	1
4	TFS63-4	DOWN-DRAFT DIVERTER (2 PC)	1 set
5	TFS63-5	DOME REAR - LOWER	1
6	TFS63-6	LINTEL	1
7	TFS63-7	DOME SIDE - LOWER & UPPER	4
8	TFS63-8	DOME SIDE - MIDDLE	2
9	TFS63-9	DOME TOP FOR 16" CLASS A CHIMNEY	1
10	TFS63-10	DOME FRONT/REAR - MIDDLE	2
11	TFS63-11	DOME FRONT/REAR - UPPER	2
12	TFS521	RATING PLATE, TFS63	1
13	APD-AC16	Ø16" DAMPER / ANCHOR PLT	---
14	BAP-IG	INSULATION BLANKET	---
15	BFP4-AK *	4 INCH DIA. OUTSIDE AIR KIT	1
16	BK63 *	STEEL SUPPORT PLATFORM 8 INCH HIGH	1
17	NOT SUPPLIED	CEMENT BOARD, TFS63	---
18	SBK-AB8 *	ASSY, FLOOR JOIST BRACE	4
19	<i>INCLUDED</i>	1/2" REBAR x 36"	10
20	NOT SUPPLIED	ALL-THREAD BAR, 1/2-13 UNC X 12"	4
21	NOT SUPPLIED	NUT, 1/2-13 UNC	8
22	NOT SUPPLIED	WASHER, Ø1/2" X 1/16	8

* ITEMS NOTED ARE SOLD SEPARATELY
 ITEMS INDICATED AS "NOT SUPPLIED" CAN BE OBTAINED FROM YOUR LOCAL HARDWARE STORE.

**Optional Outside Ø4"
 Combustion Air Kit
 Model No.: BFP4-AK**

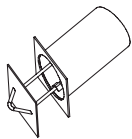

(Ø4" Ducting not included)



**FBK63SHB- Herringbone
 FBK63FRB- Running Bond**

Refractory Firebrick Liners
 (Herringbone Pattern shown, also available
 in Running Bond - see Pg.28)

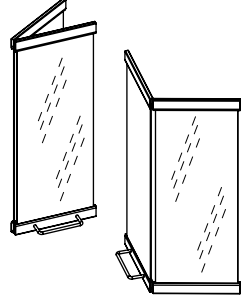

**Only the following
 doors have been tested
 and approved for use
 with this fireplace:**
 Crown-Breckinridge
 or
 McKenzie-Pendelton

Fireplace Overall Dimensions: TFS-33

Burntech® TFS33 Fireplace Overall Dimensions

Figure 7

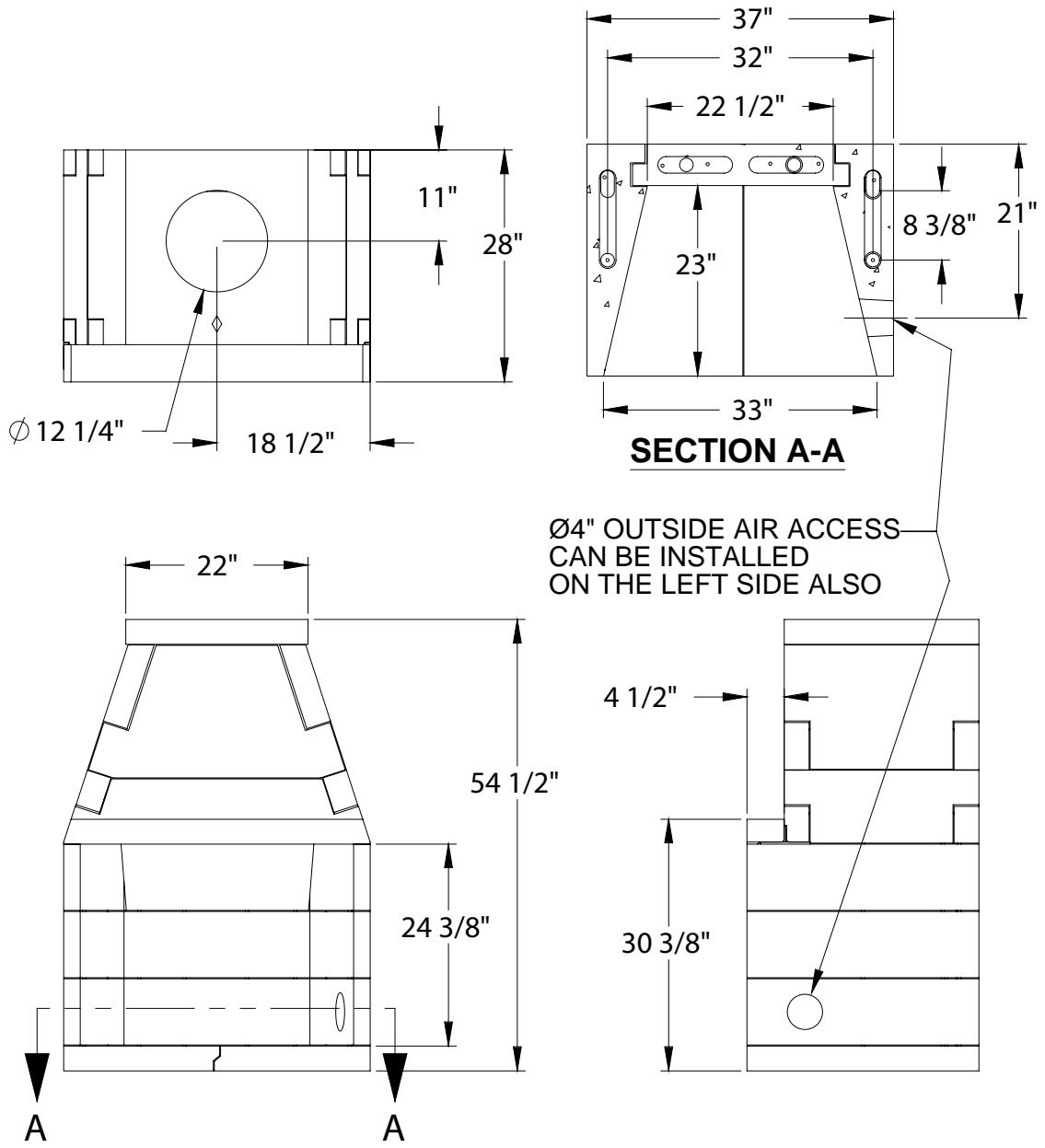

Fireplace Overall Dimensions: TFS-39/44/49

Burntech® TFS-39/44/49 Fireplace Overall Dimensions

Figure 8

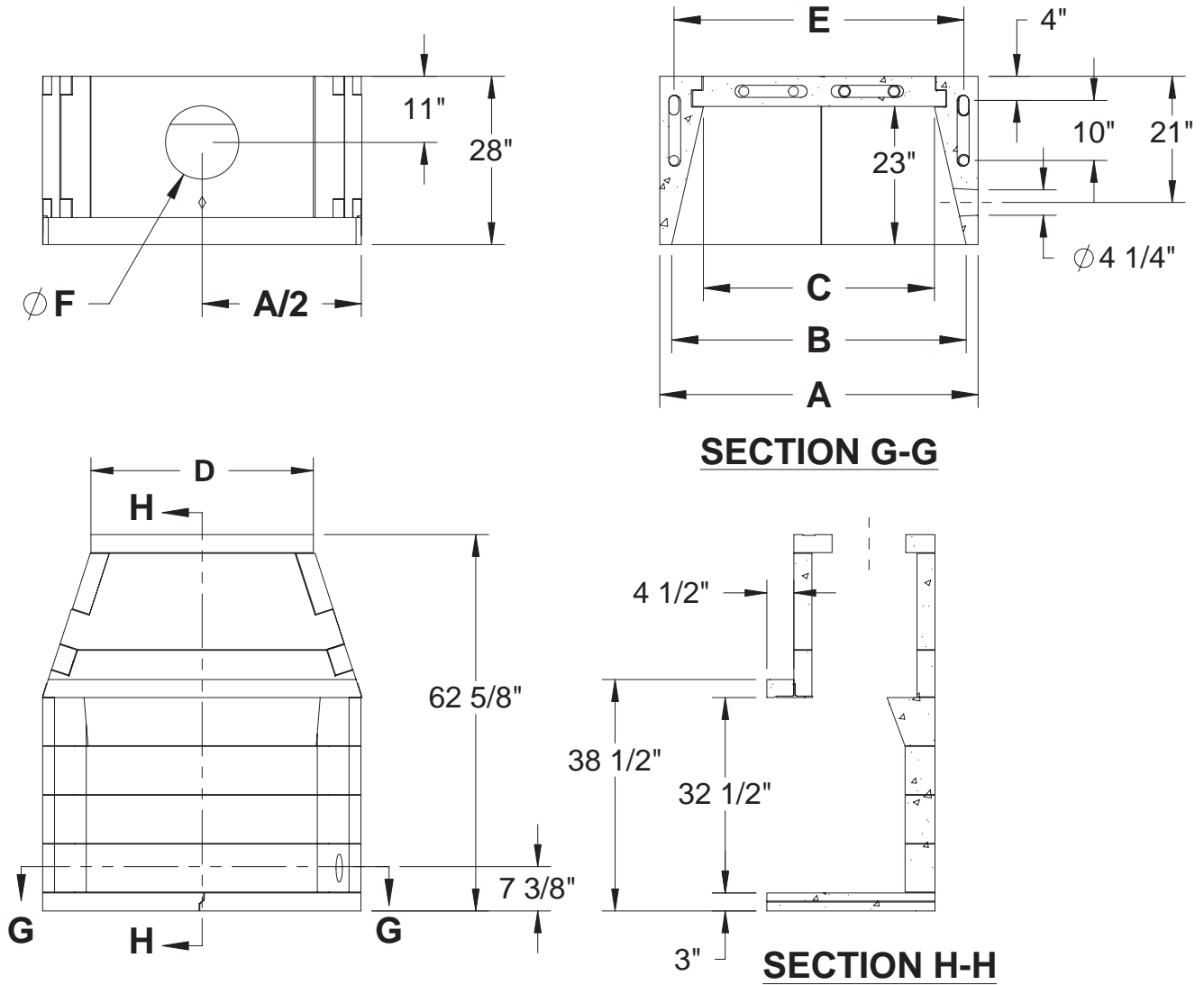

Fireplace Overall Dimensions						
Model	A	B	C	D	E	F
TFS-39	43"	39"	28-1/2"	27"	38"	$\phi 12-1/4"$
TFS-44	48"	44"	33-1/2"	32"	43"	$\phi 12-1/4"$
TFS-49	53"	49"	38-1/2"	37"	48"	$\phi 14-1/4"$

Fireplace Overall Dimensions: TFS-63

Burntech® TFS63 Fireplace Overall Dimensions

Figure 9

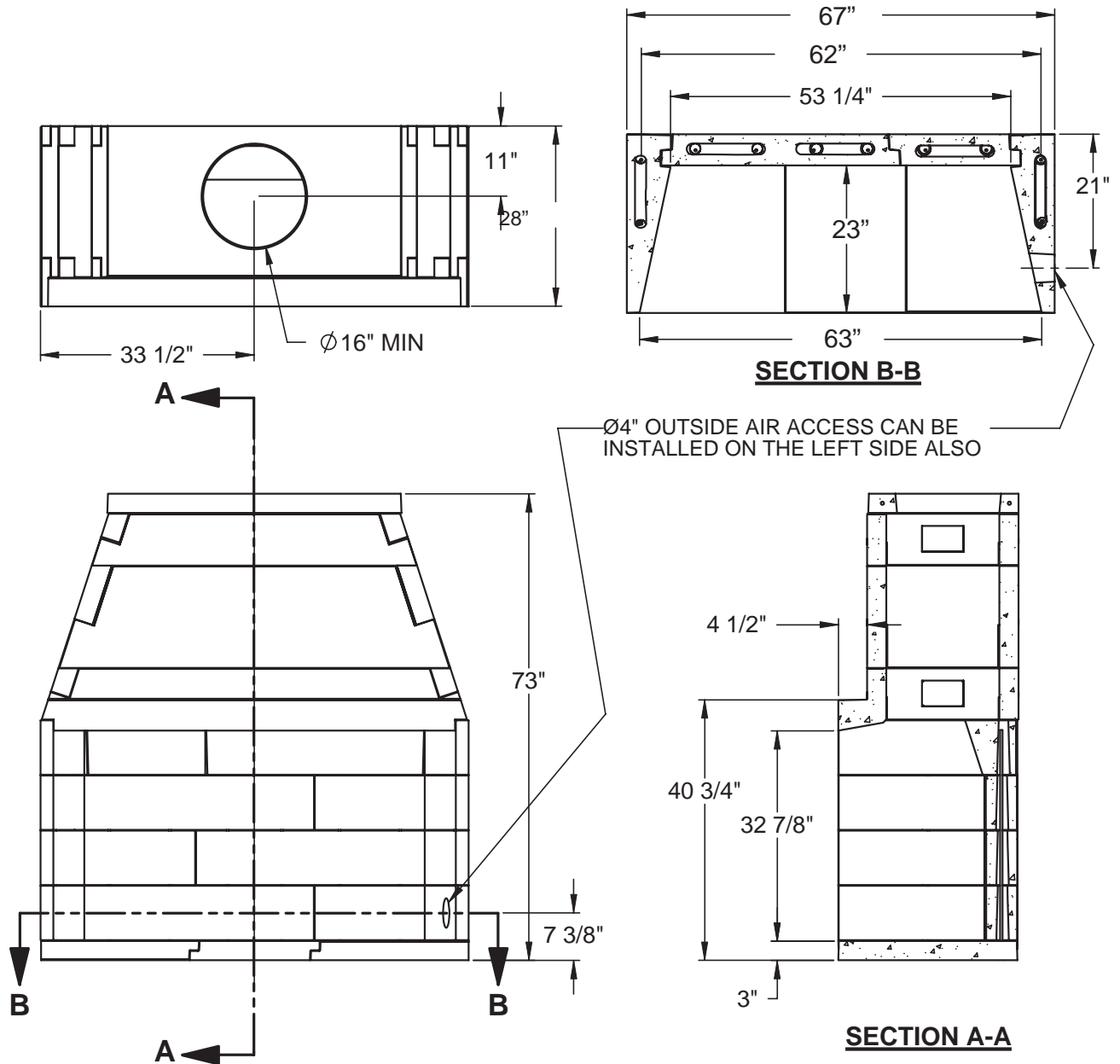

⚠ WARNING

Failure to position the parts in accordance with these diagrams or failure to use only parts specifically approved with this appliance may result in property damage or personal injury.

FOR OUTDOOR FIREPLACES CONTAINED WITHIN A FRAMED STRUCTURE REFER TO PAGES 11-16 FOR PROPER CLEARANCES TO COMBUSTIBLES.

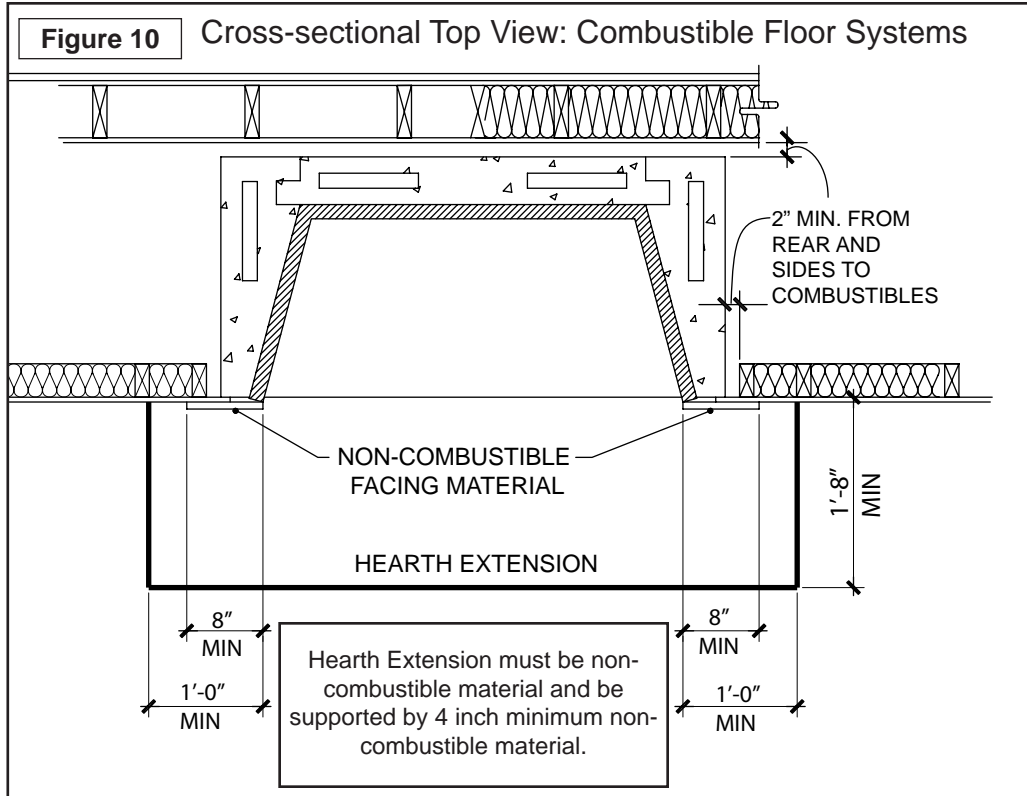

Fireplace Framing Dimensions: Non-Combustible Floor Systems

Figure 11

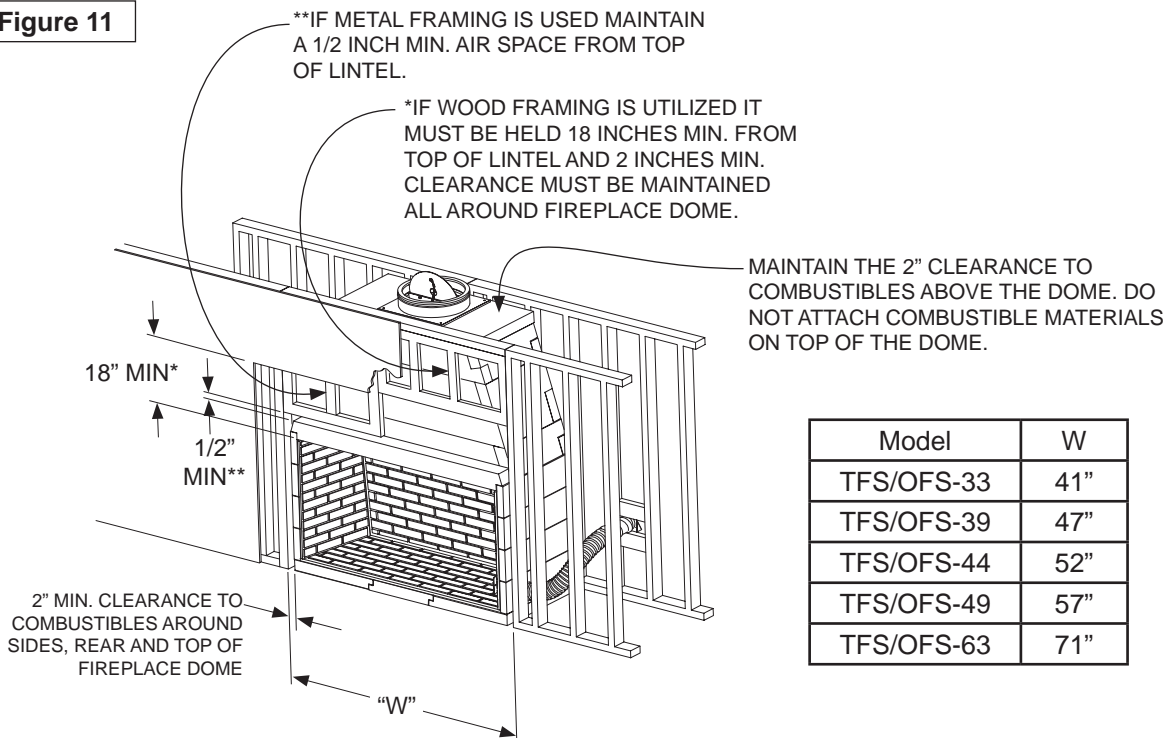
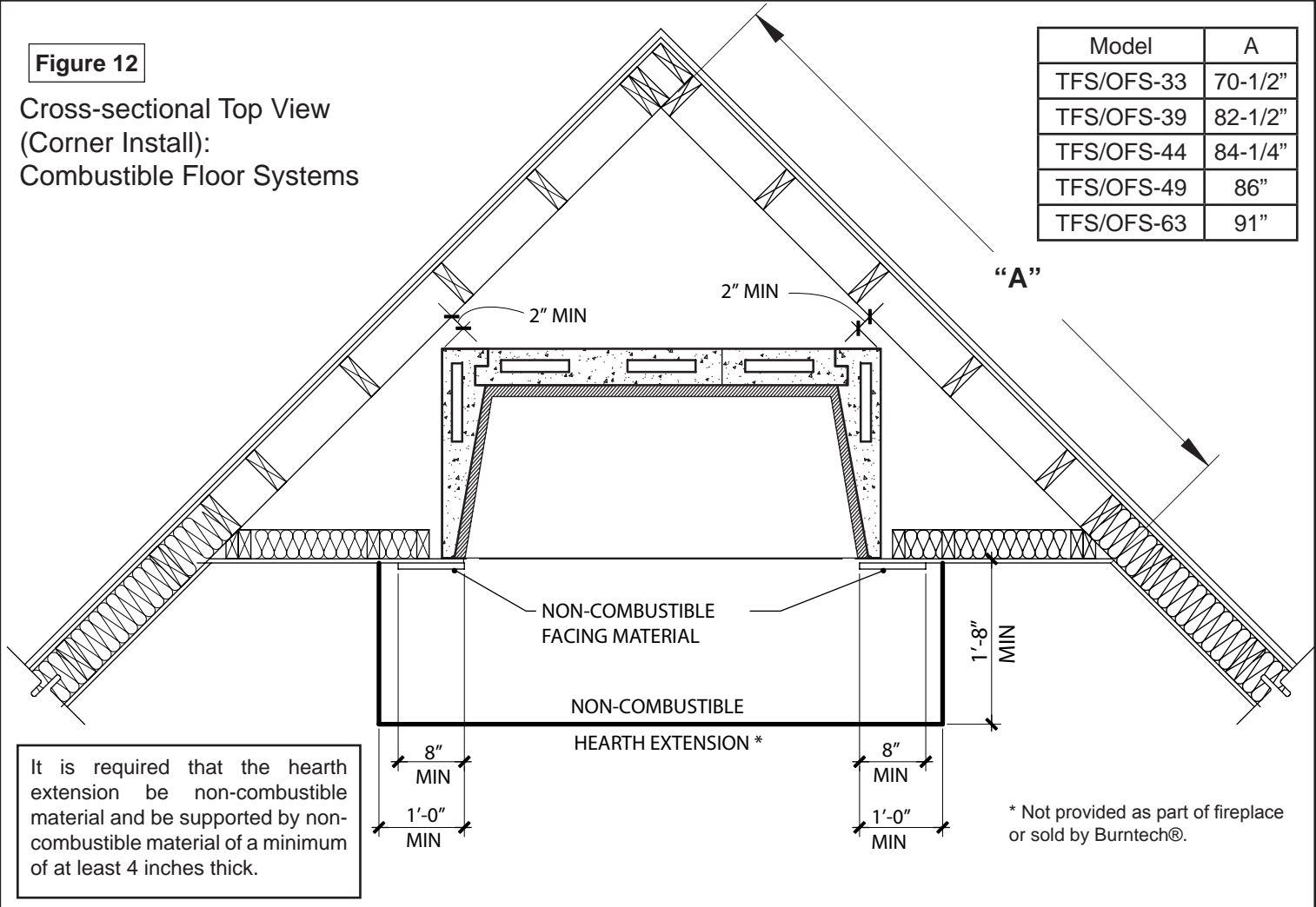

Figure 12

Cross-sectional Top View
(Corner Install):
Combustible Floor Systems

Model	A
TFS/OFS-33	70-1/2"
TFS/OFS-39	82-1/2"
TFS/OFS-44	84-1/4"
TFS/OFS-49	86"
TFS/OFS-63	91"



It is required that the hearth extension be non-combustible material and be supported by non-combustible material of a minimum of at least 4 inches thick.

* Not provided as part of fireplace or sold by Burntech®.

Figure 13

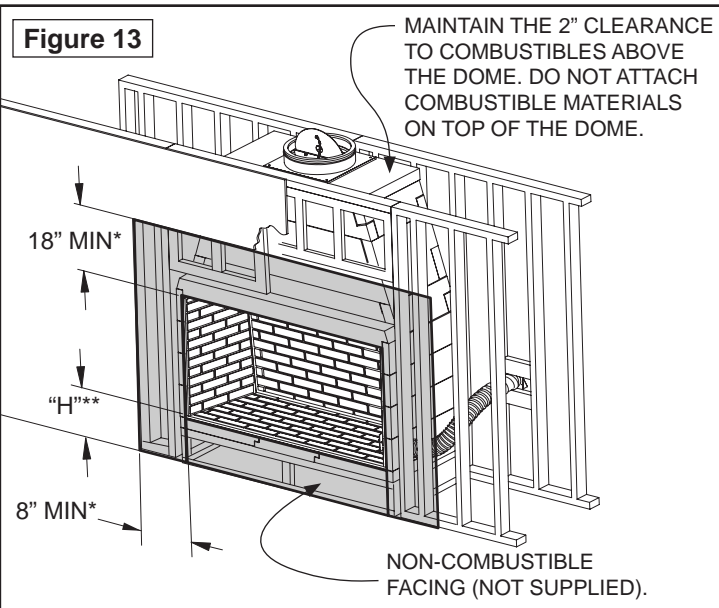

MAINTAIN THE 2" CLEARANCE TO COMBUSTIBLES ABOVE THE DOME. DO NOT ATTACH COMBUSTIBLE MATERIALS ON TOP OF THE DOME.

NON-COMBUSTIBLE FACING (NOT SUPPLIED).

Condition	Dim. "H"***
with 6" platform	10"
with 8" platform	12"
without platform	3"

* MINIMUM CLEARANCE TO COMBUSTIBLE MATERIALS.
** MEASURED FROM FLOOR TO TOP OF FIREBRICK LINER.

Where the flooring material at the opening of the fireplace is combustible, it is required that the hearth extension be non-combustible material and be supported by non-combustible material of a minimum of at least 4 inches thick. This can include an inch of marble or tile finish material. It is required that the hearth extension be non-combustible material and be supported by non-combustible material of a minimum of at least 4 inches thick. This can include an inch of marble or tile finish material.

The extension should be set flush against the front of the fireplace front and measure 20" minimum at the front (1'-8" min) and 12" minimum (1'-0" min) beyond the sides of the fireplace opening as shown in Figures 10 and 12.

If a raised hearth extension is being installed, it must be constructed of non-combustible material and any material under the structure must also be non-combustible.

If using a raised hearth or metal base plate, note that a combustible wood header must be no closer than 2" to the top of the dome (see Figure 13).

Attention: You will note that there will be a gap between the fireplace front and the extension of the non-combustible hearth material. Be certain that you seal this with non-combustible material.

Figure 14

**Cross-sectional Side View:
Non-Combustible Floor Systems**

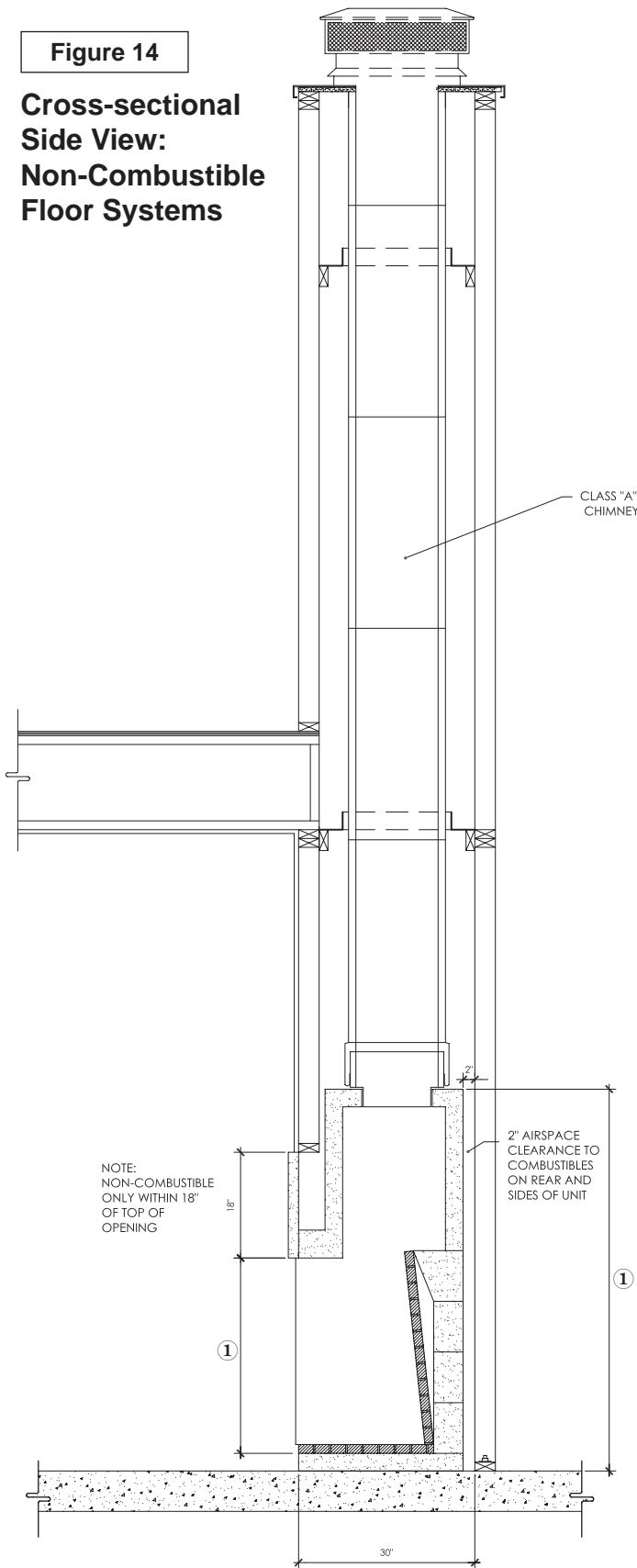
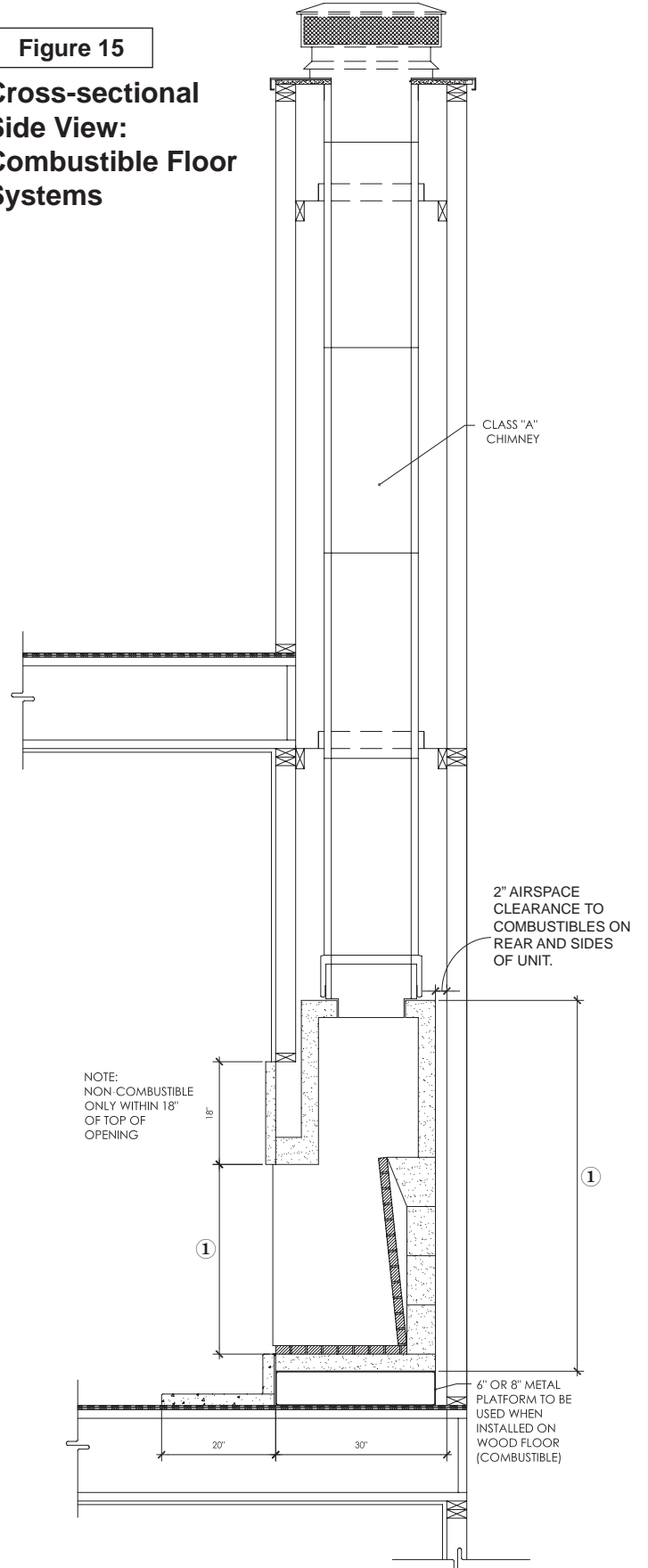

Figure 15

**Cross-sectional Side View:
Combustible Floor Systems**



① REFER TO FIREPLACE DIMENSIONS SHOWN IN PAGES 8, 9 AND 10.

WARNING: THIS FIREPLACE HAS NOT BEEN TESTED FOR USE WITH AN UNVENTED GAS LOG SET. TO REDUCE THE RISK OF FIRE OR INJURY, DO NOT INSTALL AN UNVENTED GAS LOG SET INTO FIREPLACE.

WARNING: THIS FIREPLACE HAS BEEN TESTED FOR USE WITH OPTIONAL GLASS DOORS FROM CROWN-BRECKINRIDGE OR MCKENZIE-PENDELTON ONLY.

WARNING:

For TFS-33,39,44 and OFS-33,39,44 contained within a framed structure: Install only approved, listed UL 103-12" I.D. Class A Chimney System.

For TFS-49 and OFS-44 Contained within a framed structure: Install only approved, listed UL 103-14" I.D. Class A Chimney System.

For TFS-63 and OFS-63 Contained within a framed structure: Install only approved, listed UL 103-16" I.D. Class A Chimney System.

Chimney maximum height: 40 feet

Chimney minimum height: 14 feet (with offset = 17 feet)
2 offsets maximum.

Important: Follow the chimney pipe manufacturer's instructions on the installation of their specific flue system.

GUIDELINES FOR USE:

All current and future users of Burntech® Fireplaces are charged with the responsibility for full knowledge of the information contained within this manual which includes:

Strict requirements for assembly.

Detailed instructions for installation.

Cautionary guidelines for use.

On-going maintenance instructions.

It is the responsibility of the installer, subcontractor and/or the general contractor – whoever shoulders the liability for installation of this product – to see to it that the work is in complete compliance with the guidelines and instructions in this manual. Note that the general contractor is the party accountable for seeing that adequate clearances are provided from all firebox surfaces per specifications in this manual.

DO NOT USE A FIREPLACE INSERT OR OTHER PRODUCTS NOT SPECIFIED FOR USE WITH THIS FIREPLACE.

The Burntech® is Designed for Use Only with:

- Solid Wood Logs
- Plumbed LPG or Natural Gas Log Lighter.
- Plumbed ANSI Z21.60 Decorative Gas Log.

DO NOT USE OR STORE GASOLINE OR OTHER FLAMMABLE LIQUIDS OR GASES IN OR NEAR THE FIREPLACE!

ATTENTION: A fire or an explosion could occur causing property damage, injury or loss of life if you do not follow the information in this manual!

NOTE: THIS MANUAL MUST BE REPRODUCED ONLY IN ITS ENTIRETY.

Before Beginning the Installation

Read these instructions carefully before beginning the installation of this fireplace. Also, if installing an ANSI Z21.60 Decorative Gas Log, read the gas log appliance manufacturer's literature regarding sizing and suitability for the installation into this enclosure prior to installation.

Statement of Intended Use:

The Burntech® Masonry Fireplace is a modular refractory masonry unit designed for field assembly. The firebox is constructed using pre-cast, interlocking refractory blocks. The blocks are then secured to each other using Mortar. The system includes all parts necessary for the assembly of a complete masonry fireplace. In addition to the basic enclosure, a standard 1-1/8" thick, high temperature refractory brick is required to line the interior of the firebox and can be purchased from the manufacturer.

These fireplaces are not intended to serve as a primary heat source, rather, the fireplace was expressly created as a supplemental source of heat. The unit is designed for use with solid fuels such as cord wood.

WARNING:

Any application other than the "Intended Use" as stated above is in violation of the manufacturer's instructions and is hereby prohibited. Such violation may cause immediate hazard, property damage or loss of life and will void all liabilities to the manufacturer and will void all warranties explicit or implied.

Introduction

Thank you for choosing Burntech® Fireplace Solutions for your masonry fireplace needs.

Rest assured that every component of the Fireplace has been tested to ensure long-term durability.

Product Overview

Burntech® Fireplaces are designed as factory-built blocks to be assembled on-site. These fireplaces may be installed on either combustible or non-combustible floors. In order for the fireplace to be installed on a combustible floor though (TFS models only), it is necessary that the fireplace be supported on a platform or sub-floor that is non-combustible.

The Four Components of the Burntech® Fireplace:

- Combustible or Non-Combustible Floor (TFS models only)
- Non-Combustible Raised Platform (optional)
- Burntech® Masonry Fireplace
- UL103 class A listed chimney system required.
Important: Follow the chimney pipe manufacturer's instructions on the installation of their specific flue system.

- or -

- Burntech® Masonry Chimney System

Careful step-by-step instructions for each phase of the installation procedure will be given for the Burntech® conventional radiant heat fireplaces. Those instructions generally fall into the following categories:

- Spacing and clearance as it relates to combustible materials.
- Familiarity of installation for all components.
- The strength of the floor on which it rests.
- Chimney system measurements.
- Choice of materials and craftsmanship in fireplace and hearth finishing.

Figure 16 - Typical Installations

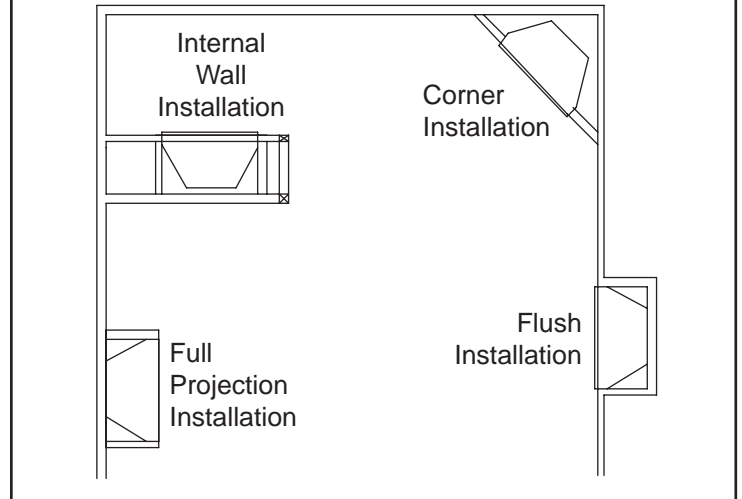

Note that each of these topics will be covered in detail and that the installer is expected to understand each phase completely before going on to subsequent instructions.

Attention: Be advised that all the illustrations in this manual are for general reference only. Do not scale drawings. Actual design elements will vary from case to case. Pay attention to specified minimum clearances to combustibles.

Testing and listing for these Burntech® Fireplaces have been tested by and are listed under PFS, Inc.

Attention: You may need a residential building permit or Deputy Inspector to install a Burntech® Fireplace. Consult local jurisdictions before you get started!

If asked, advise the local authorities that the Burntech® Fireplace is designed for installation per the National Fire Protection Association Standard for Chimneys, Fireplaces, Vents and Solid Fuel-Burning Appliances (NFPA211).

When choosing the location of your Burntech® Fireplace, keep in mind you must maintain 2" (two inches) minimum clearance from left, right and rear of Fireplace to surrounding structure. Also, when choosing a location, consider outside air requirements to determine if it will be on the left or right side of the Fireplace. In the case of an island installation, outside air accessibility may be obtained through sub flooring. See section on Installing Outside Air on page 28.



Clearances to Combustibles

Proper Clearances to combustible material must be maintained at all times. Here are some common combustible construction materials:

Drywall	Wood flooring	Plywood
Sub-flooring	Wood Framing	Particle board
Mill board	Plywood paneling	

Maintain the following clearances:

- Unit sides, rear, Dome sides, rear & top: 2" (51 mm)
- Combustible Floors (TFS/OFS-33,39,44,49): 6" (152 mm)
- Combustible Floors (TFS/OFS-63 only): 8" (203 mm)
- Combustible Sheathing above opening top: 18" (457 mm)
- Sheathing or trim to opening sides: 8" (203 mm)
- Mantel above opening: (see Fig.17)
- Opening to sidewall: 24" (610 mm)
- Hearth extension beyond front: 20" (508 mm)
- Hearth extension beyond sides: 12" (305 mm)
- Insulation from firebox: 2" (51 mm)

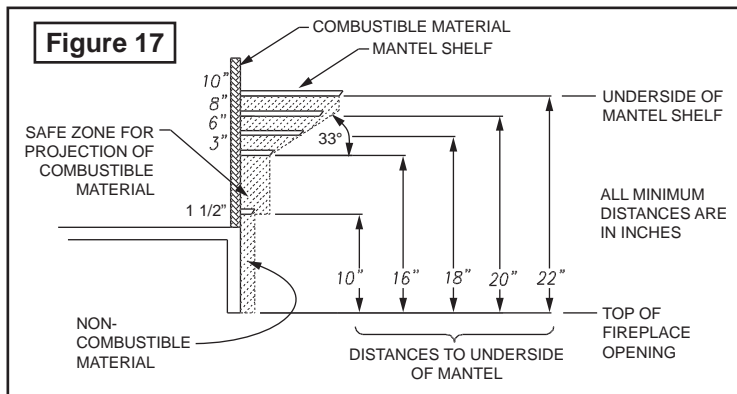

Understanding Clearance to Combustibles

There is a build-up of a considerable amount of radiant heat on the outer surfaces of the Burntech® Fireplace. It's critical that proper clearances to combustibles be maintained so that this radiant heat is maintained to safe limits.



Combustible Floor Clearances

*TFS Models only. OFS Models are not approved for combustible floor installation.

These Burntech® Fireplaces have been designed with clearance to combustible floors as indicated in Page 19. Cover any part of the combustible floor system left exposed with 1" (one inch) thick ceramic fiber insulation rated up to 2,100° F.

Attention: It is critical to abide by the clearances listed in this manual for all components specified as it allows for movement of hot air from the fireplace into interior areas of the chimney chase. Also, be certain that the chimney system be installed as stated below. Prior to starting the installation, check with local, regional or state codes for any restrictions or required permits regarding your fireplace installation.



Burntech® Fireplace & Chimney System

- 1) This Burntech® fireplace is designed to be installed with a listed UL103 - Class A, Metal Chimney System.
- 2) This Burntech® fireplace is intended as a supplemental heat source only. It is not intended as a primary heat source.
- 3) It is the responsibility of the contractor installer (not the manufacturer) to ensure that adequate combustion air is provided for proper function of this fireplace. Fireplaces take up a large volume of replacement air from outside the house and if the house is of airtight construction, smoke spillage may occur if proper draft is not achieved.
- 4) There are many conditions beyond the manufacturer's control regarding improper fireplace operation. The manufacturer cannot ensure "smoke free" operation, nor can the manufacturer take on the responsibility for problems with surrounding construction; chimneys that have not been built at the correct heights; system drafts caused by faulty mechanical systems; adverse weather conditions or any other environmental situations over which the manufacturer has no control.
- 5) Inspect all fireplace & chimney components for evidence of damage prior to starting installation. Consult your local distributor for replacement parts if necessary.
- 6) Under no circumstances should you make any adjustments or modifications to the chimney system during the installation procedure. If you do, you are not only liable for negating the warranty, but you could very well cause a serious malfunction of the fireplace. You must follow these chimney instructions.
- 7) Caution is urged if it is decided to add insulation material near any part of the Burntech® Fireplace or Chimney system, be certain that the insulation material is kept at least 2" (two inches) away from any part of the system. When using insulation or vapor barrier materials, cover with a layer of plywood, particle board or gypsum board to maintain the specified 2" (two inch) clearance.
- 8) Air spaces around fireplace must remain open. DO NOT fill these open spaces with insulation or packing material of any kind.



Chimney System Heights

When installed, the **maximum** overall height of the chimney system from bottom of fireplace to the top/termination chimney is 40 feet. The **minimum** installed height of the completed Chimney System is 14 feet with a straight flue stack, 17 feet if the chimney includes one or two offset sections.

Supporting Floor Systems

It is the ultimate responsibility of the installer to ensure that proper concrete slab supports are used.

WARNING: Combustible floor installations are limited to TFS models only. To the licensed design professional and/or building contractor: It is your responsibility to be certain that the Burntech® can be properly supported by the combustible floor system on which the fireplace will rest.

For fireplace support foundations installed on concrete refer to Appendix I and II (pages 32 & 33) for specific instructions.

Rebar locations

Lay-out the position of the fireplace and drill holes where the rebar will be located. Secure the 1/2" Rebar 4 inches into the concrete foundation with Epoxy. Be sure to consult with your engineer or local building official for the correct Epoxy formula. Follow manufacturer's instructions for installation of rebar into slab.

Wood Floor*

*Wood floor installations are limited to TFS models only. Anchorage of fireplace to wood floor construction is required. Refer to **Figure 21** for anchorage dimensions. Four anchors are required to attach to the sub-flooring framing.

Crawl Space or Upper Floor*:

*Crawl space or Upper Floor installations are limited to TFS models only. For installation of firebox over combustible crawl spaces or upper floors, anchorage of the firebox is required. Illustrations of examples of possible anchorage methods are shown in Figures 18 thru 20 depending upon the type of floor framing. Final method of anchorage is to be determined by licensed design professional.

For conventional framing, where the floor joists are parallel with the sides of the firebox, the addition of floor joists to align with the anchor brackets allows the brackets to be directly connected to the floor joists.

Note that additional floor joists may be required to support the weight of the firebox and chimney. Where the floor joists run parallel to the front of the firebox, anchorage can be accomplished in like manner as shown in Figure 18 using blocking between the floor joist.

For floors supported by I-Joists, the method of anchorage is illustrated in Figures 19 and 20. Figure 23 illustrates the general arrangement of anchorage to floor framing.

It is important to take into consideration that the load for the Burntech® Fireplace must be considered as additional dead load that will have to be supported by the floor framing. Additional floor joists or I-joists may be required as determined by the licensed design professional.

The dead weights for the fireplace are noted in Table I. It is the task and responsibility of the general contractor/installer to see that the proper reinforcement for weight loads are made by a licensed design professional prior to the fireplace installation.

As stated above, it is desirable to place additional framing for alignment of anchor rods. Refer to Figure 21 for anchor rod locations.

Attach the firebox side wall anchors to steel support frame by inserting all-thread rods through holes on the bottom flange on the steel support frame as shown in Figure 24 and 25. Secure with two $\varnothing 2"$ o.d. x $\varnothing 9/16"$ i.d. x 0.10" Washers and two 1/2"-13 UNC Nuts.

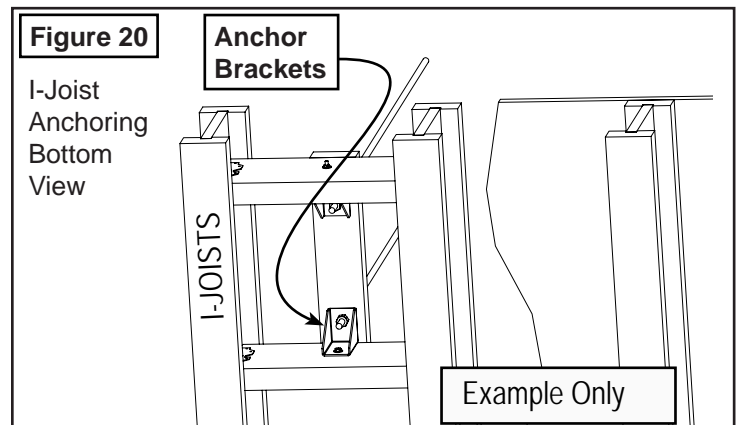
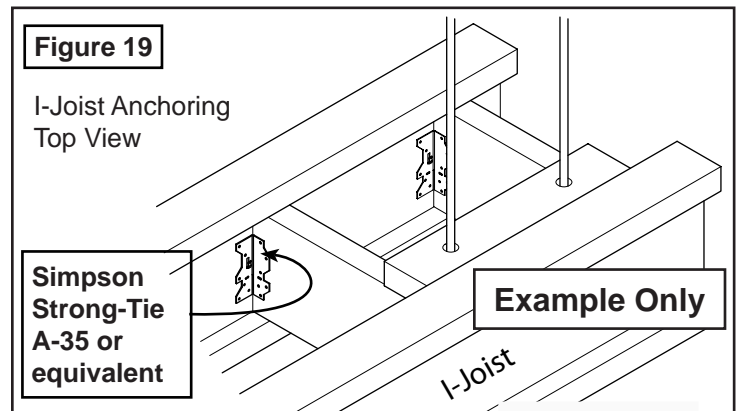
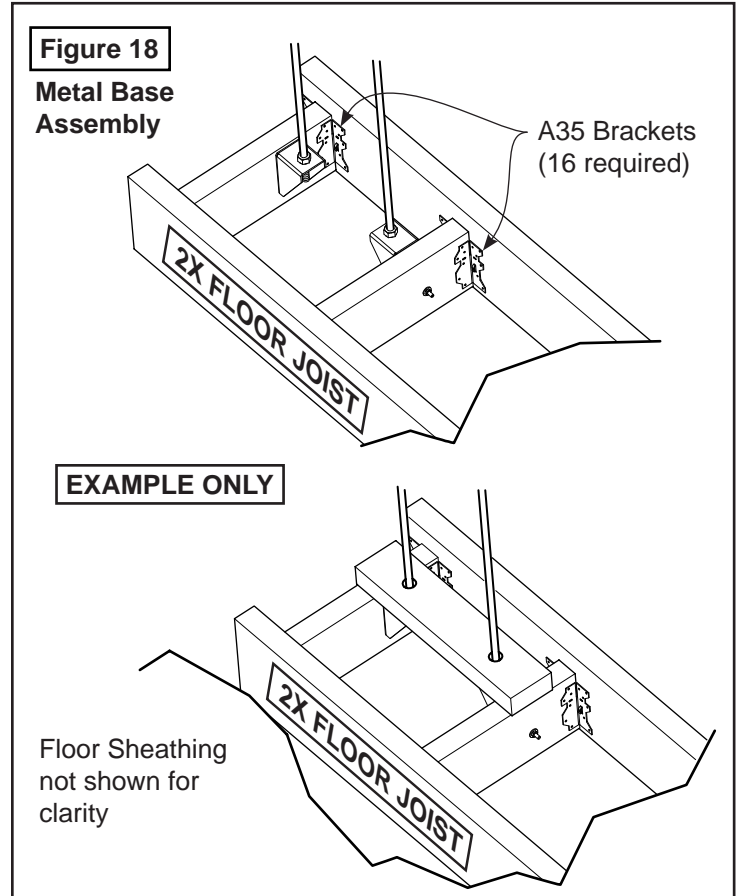

Burntech® Weight Determination

The following are dead load weight estimates for the Burntech® Fireplace.

Table I					
Fireplace Model	TFS-33	TFS-39	TFS-44	TFS-49	TFS-63
Fireplace Weight	835 lbs.	1,194 lbs.	1,250 lbs.	1,359 lbs.	1,704 lbs.
Mortar, Rebar & Ready Mix Concrete	200 lbs.	350 lbs.	357 lbs.	364 lbs.	370 lbs.
Firebrick Lining	290 lbs.	333 lbs.	345 lbs.	356 lbs.	435 lbs.
Damper/Anchor Plate	17 lbs.	17 lbs.	17 lbs.	17 lbs.	21 lbs.
Steel Platform	89 lbs.	94 lbs.	96 lbs.	100 lbs.	132 lbs.
Floor Area	37" x 28" (7.2 ft ²)	42" x 28" (8.12 ft ²)	48" x 28" (9.33 ft ²)	53" x 28" (10.30 ft ²)	67" x 28" (13 ft ²)

Other Weight Considerations:

- 1) Fireplace finished facing (surround): This information needs to be obtained from the contractor.
- 2) Weight of metal flue: See chimney manufacturer's weight specifications. Some chimney systems can weigh up to 50 lbs per lineal foot.

Table II - Deflection Limits			
Construction	L	S or W	D + L₁
Floor Members	I/360	---	I/240

¹ For wood structural members having a moisture content of less than 16 per cent at time of installation and used under dry conditions, the deflection resulting from $L + 0.5D$ is permitted to be substituted for the deflection resulting from $L + D$.

Note that Burntech® cannot accept responsibility for structural floor support details. All drawings are presented as mere illustrations to indicate the presence of the underlying floor system. It is the responsibility of the general contractor/installer to consult with a local licensed design professional for guidance in building a proper floor support system.

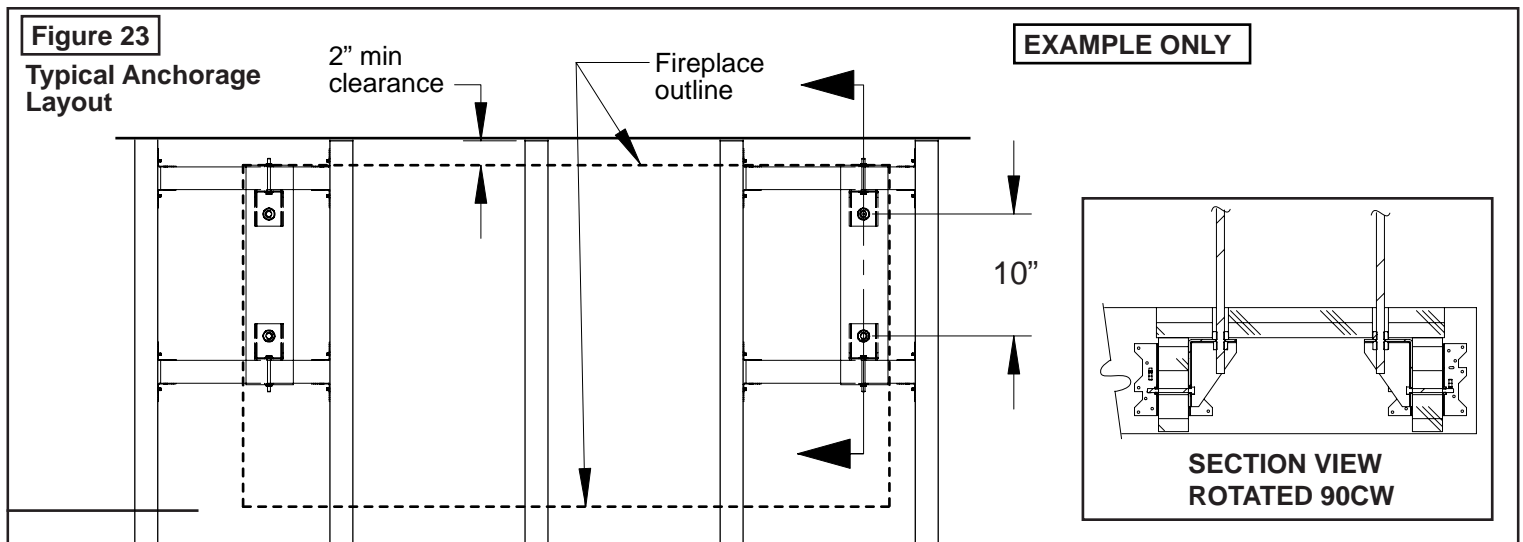
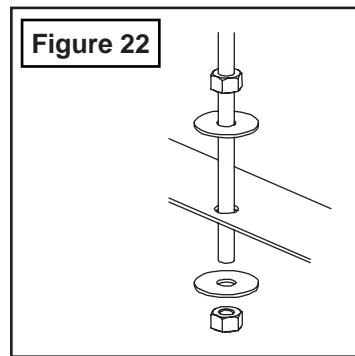
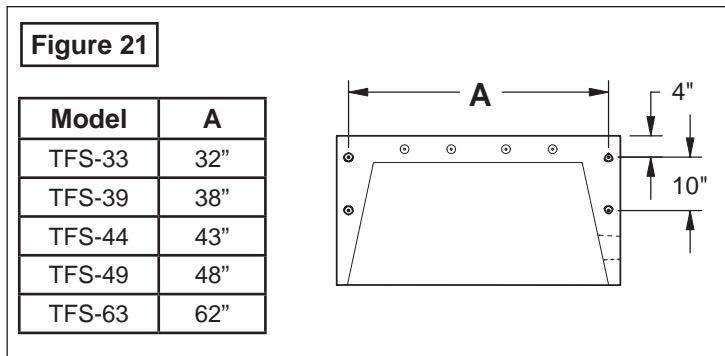



Combustible Floor Installations

WARNING: Combustible floor installations are limited to TFS models only.

8" Metal Base (TFS-63)

The TFS-63 Burntech® Metal Base (TF63) ensures the minimum **eight inch clearance** above combustible flooring is maintained.

A layer of 1/2" minimum Concrete Board is required on the top and mid section below as shown in Figure 24. The required sizes are shown in the table below.

1/2" Thick Cement Board Dimensions				
Model	A1	A2	B1	B2
TFS-63	67"	28"	60"	23"

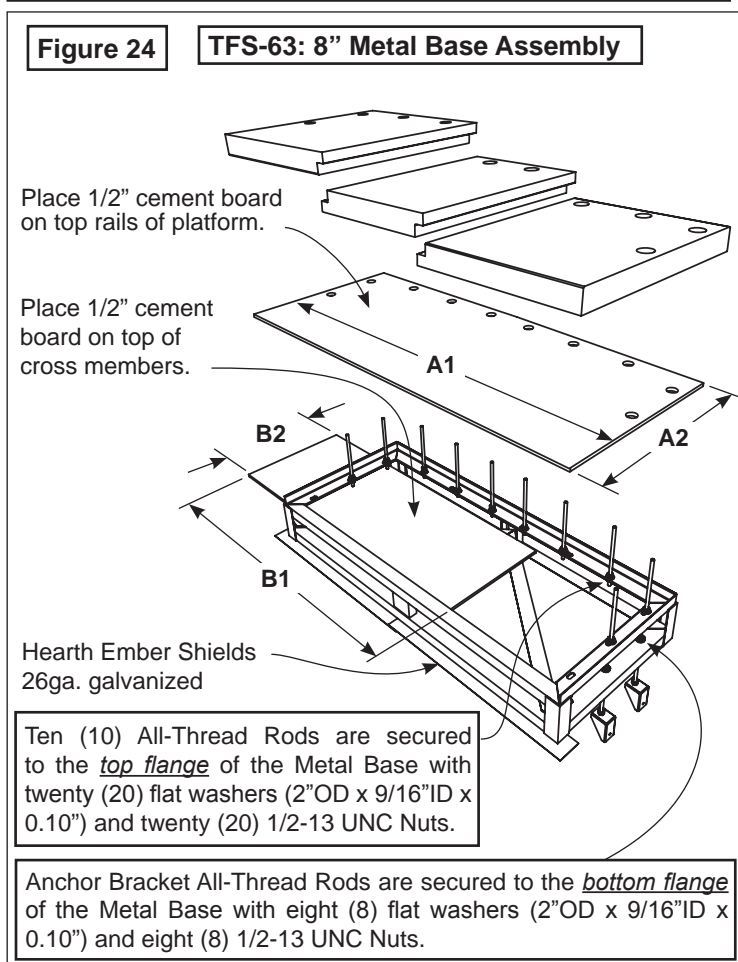

▲ IMPORTANT:

Remember to tighten up nuts below the floor after fireplace installation in order to take up any slack in the threads.

Hearth Ember Shields:

Metal safety stripping is required between the front of the Fireplace Hearth and Hearth Extension (not supplied). A 26 gauge galvanized 4" wide metal strip can be used. The length needs to extend 2 inches beyond each side of the fireplace opening. If two strips are used, make sure they overlap at least two inches in the middle. The strip is placed about 2" into the underside of the platform at the front.

Note: When using an on-site constructed hearth extension, you may use a sand-cement grout between the hearth and extension instead.

6" Metal Base (TFS-33/39/44/49)

The Burntech® Metal Base ensures the minimum **six inch**

6" Metal Bases	
Model	P/N
TFS-33	TF63B33
TFS-39	TF63B39
TFS-44	TF63B44
TFS-49	TF63B49

clearance above combustible flooring is maintained.

A layer of 1/2" minimum Concrete Board is required on the top and mid-section of the Metal Base as shown in Figure 25. The required sizes are shown in the following table:

1/2" Thick Cement Board Dimensions				
Model	A1	A2	B1	B2
TFS-33	37"	28"	30"	23"
TFS-39	43"	28"	36"	23"
TFS-44	48"	28"	41"	23"
TFS-49	53"	28"	46"	23"

Note: The insulation (concrete) board chosen must meet a thermal conductivity rating ≥ 0.4 Btu-in/hr-ft²-F°.

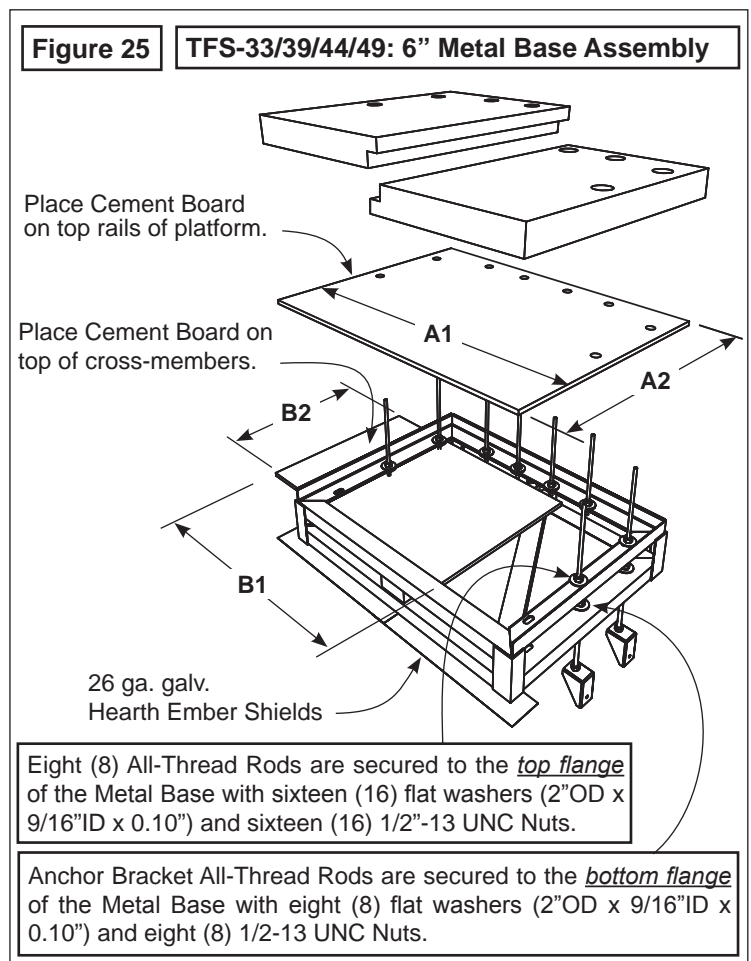



What You Will Need

You will find that the Burntech® Fireplace is designed to be completely assembled on-site, consisting of interlocking precast parts. You will need a thin-set type mortar for bonding. The parts of the fireplace are made of Burntech®'s incredibly strong blend of specialty cement and a light weight aggregate.

IMPORTANT! When applying mortar, it is imperative that the concrete blocks be maintained moist (not soaking) so they don't absorb the water out of the mortar and cause adhesion to fail. Frequently run a damp sponge to the parts before mortar is applied!

On TFS models, installation of an anchor plate and damper are required but not supplied. On OFS Models, anchor plates and Class A UL 103 listed chimney is required for installation within a framed structure.

You may purchase chimney from Burntech® Fireplace Solutions. Also, a combustion air inlet BFP4-AK can be obtained from Burntech® Fireplace Solutions but are not required on most outdoor fireplace installations.

Note: Dampers and outside air kits are not required on most outdoor installations. Consult with your local building department.

Refractory Firebrick Liners also need to be installed. These should be a minimum of 1-1/8" (one and one-eighth inches) thick. The liner will be applied within the walls and hearth area of the firebox. These are available from Burntech® Fireplace Solutions. Standard masonry firebrick may also be used instead of Burntech® Refractory Brick Liners. See page 28.

Tools needed for installations:

- One 4' level
- Roto-hammer with 1/2" drill bit (needed for concrete slab install only)
- Drill motor with mixer blade (to mix Burntech® Mortar)
- Two empty 5 gallon buckets (to mix Burntech® Mortar)
- One wheelbarrow and shovel to mix concrete.
- Grout bag
- Triangular masonry trowel
- Rubber hammer
- Sponge and water bucket to wipe down and moisten parts prior to applying mortar.

Materials needed for concrete slab (non combustible) installation

TFS/OFS 33:

Six (6) pieces 3/8" rebar x 28" long (included with unit)

Six (6) pieces of rebar x 12" long (included with unit)

TFS/OFS 39:

Six (6) pieces 3/8" rebar x 36" long (included with unit)

Six (6) pieces of rebar x 12" long (included with unit)

TFS/OFS 44/49:

Eight (8) pieces 3/8" rebar x 36" long (included with unit)

Eight (8) pieces of rebar x 12" long (included with unit)

TFS/OFS 63:

Ten (10) pieces 3/8" rebar x 36" long (included with unit).

Ten (10) pieces of rebar x 12" long (included with unit)

ALL UNITS:

- Epoxy for securing rebar in footing / foundation.
- Three (3) - 90 lb. bags of Ready-Mix Concrete with 1/4" or smaller aggregate.
- Burntech® Mortar (one 50 lb. bag for TFS-33/39/44/49 or two 50 lb. bags for TFS-63).

Materials needed for combustible wood floor installation (TFS models only):

TFS33:

Six (6) pieces 3/8" rebar x 28" long (included with unit)

Six (6) ea. All-thread x 12" long (with nuts and washers)

Metal base - 6 inch.

TFS39:

Six (6) pieces 3/8" rebar x 36" long (included with unit)

Six (6) ea. All-thread x 12" long (with nuts and washers)

Metal base - 6 inch.

TFS44/49:

Eight (8) pieces 3/8" rebar x 36" long (included with unit)

Eight (8) ea. All-thread x 12" long (with nuts and washers)

Metal base - 6 inch.

TFS-63:

Ten (10) pieces 3/8" rebar x 36" long (included with unit).

Ten (10) ea. All-thread x 12" long (with nuts and washers)

Metal base - 8 inch.

ALL UNITS:

- 1" ceramic fiber blanket the size of the hearth base to go under the metal base.
- 1/2" cement boards (cut to size).
- Four or more fasteners to attach metal base to floor joists
- Burntech® Mortar (one 50 lb. bag for TFS-33/39/44/49 or two 50 lb. bags for TFS-63)
- Three (3) - 90 lb. bags of ready mix concrete with 1/4" or smaller aggregate.



Field Assembly Procedures

- Mixing the Burntech® mortar – The mortar comes premixed and should be dry. Be sure to use clean water and work it up into a mixture that is pasty but not lumpy. If it's too thin and the surfaces don't stay moist, the components will not adhere. Load the mixture into a standard grout bag.
- Apply 1/2" (one-half inch) bead of mortar. The mortar bead should be approximately 1/2" (one-half inch) away from all edges. The mortar has a considerable amount of holding power so do not overload the components with too much mortar. Keep the components moist at all times!
- Some mortar will "ooze out" when placing components together, this is normal. Wipe excess away with a trowel. Do not cover component surfaces completely with mortar. Do not apply the mortar in thick bands even if the component you are working with is larger than the rest. You will want to apply "stripes" of mortar in these situations.
- Make sure components are level. It's extremely important that you pay careful attention to how you are assembling the Burntech® Fireplace since every component builds on the next. If you have to make any kind of an adjustment, do not try to do it "by loading an opening" with mortar, this will only result in a fireplace that will not be plumb or level.

Use wood shims instead. **You will find these small wood shims supplied with the Burntech® Fireplace** and you can nudge them in between openings to achieve the precision you need in making component adjustments. Once you have removed any shims, you will want to cover any gaps that may have resulted with the mortar.

- Before installing side walls, confirm placement of outside combustion air access (if required), this can be installed either side depending on which side is accessible to outside combustion air (all diagrams in this manual show the combustion air inlet hole on the right side). Prepare side wall and rear wall mating surfaces with the prepared mortar and begin assembly.

OFS TFS/OFS-33/39/44/49 Fireplace Assembly

Assembly Instructions

- Place the Burntech® Fireplace hearth base on top of your non-combustible floor or metal base. For concrete slabs, supporting floor needs to be rated at ASTM 90.
- Combustible Floor Installations (TFS Models Only):** Mix up a batch of mortar and adhere hearth slabs to the cement board (see Figure 25). All-thread rods should stick up through the holes on the hearth slabs.
 - Concrete Floor Installations:** Draw an outline of the hearth area based on the dimensions shown in pages 8 and 9. Position Hearth slabs and mark rebar center locations. Drill 4 inches into concrete slab and secure the 8 pieces of 12 inch rebar with epoxy.

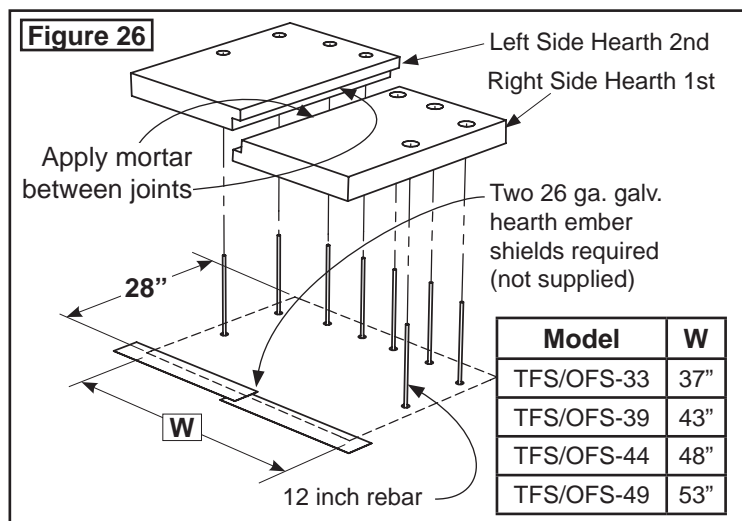

- Mix a batch of mortar and prepare Right Side Hearth bottom surface to be bonded as shown in Figure 27.
- Align Right Side Hearth to the outline created. The overall width should allow for an approximate gap of 1/8" between slabs for the additional mortar to unite the remaining slab. Check for surface flatness, level if necessary.

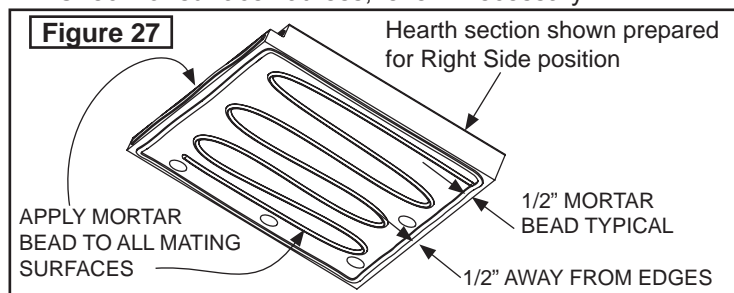

- Apply mortar to the remaining Hearth except this time apply beading on surface to be facing floor as shown in Fig.28.

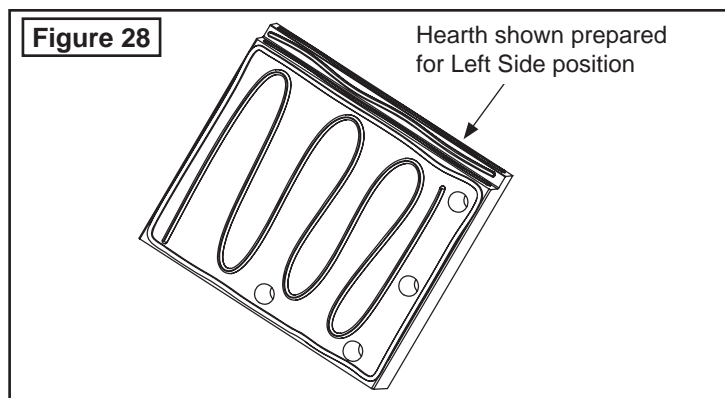

- Keep the assembly of the next sections of the firebox side walls moving up, keeping components moist, mixing mortar as you need it and threading the mortar appropriately as you stack each section, one onto the next. Constantly check for squareness and levelness while building each course of block. As you complete each section, make certain that you adhere the mortar at each and every joint.

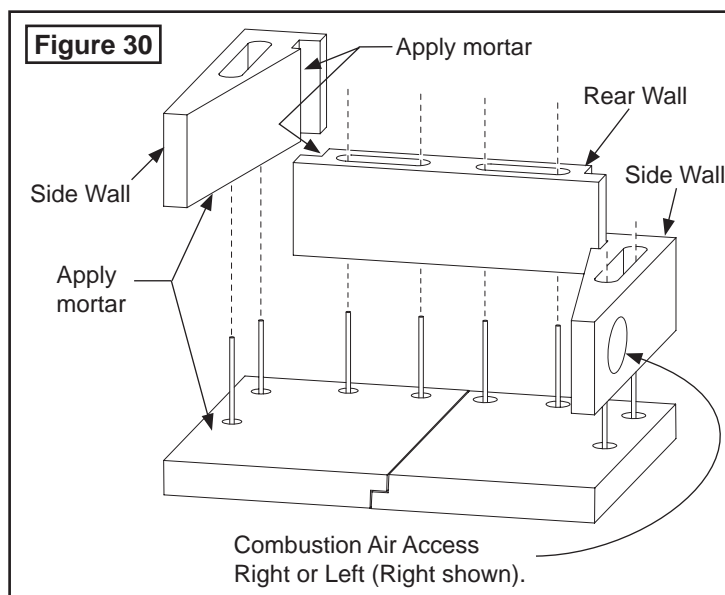
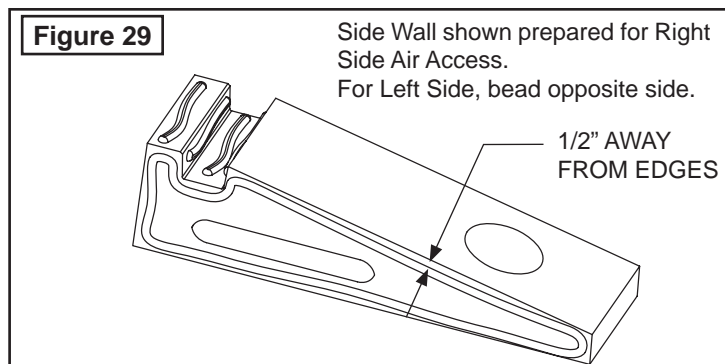

For TFS/OFS-33 installation continue to next page, for TFS/OFS-39/44/49 installation turn to page 23.

8. **TFS/OFS-33 ONLY:** After the second row of firebox is complete, install Smoke Shelf and remaining side walls (Figure 31). Mix approx. 2 cu. ft. of Ready-Mix Concrete. Insert 28" rebar vertically through the cells, into the holes in the hearth, adjacent to the rebar and/or all-thread sticking up from the hearth. Fill all cells with Ready-Mix Concrete mix.

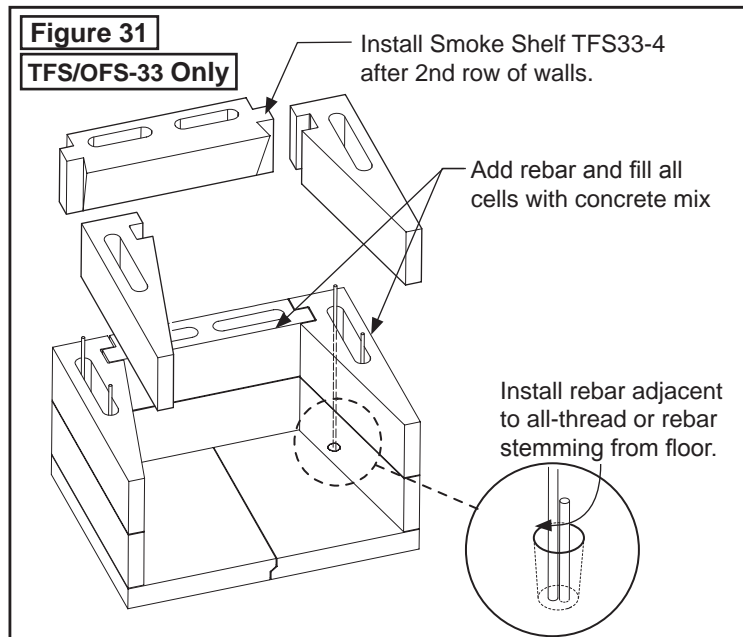

9. Set the Lintel and Lower Rear Dome in place as shown in **Figures 32**. Check that all is level. If you need to make adjustments, use shims. Place one or more of these shims between the lowest wall component and the top surface of the base plate. Once you are satisfied with the degree of levelness, you can address any gap that may have occurred with an appropriate amount of mortar.

Note: Although you are cautioned to use Burntech® mortar sparingly because it does have such holding power, you should look over the firebox assembly at the end and fill in any gaps, especially joint connections, with the mortar.

Important: Adjustments can only be made while the mortar is still wet when correcting for squareness and leveling.

10. Assemble Lower Dome Sides as shown in **Figure 32**. The beveled face lines up with the inward angles of the lintel sides. Top surfaces should be level.

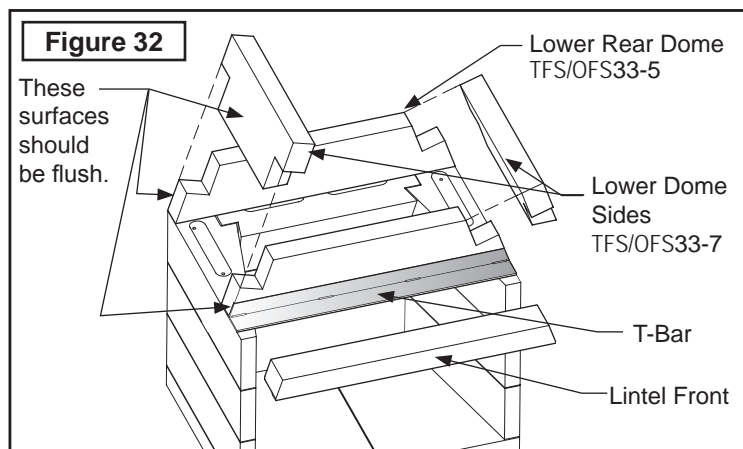

11. As you are connecting each Burntech® component, be certain you are following the instructions given previously for using Burntech® mortar. Stop to look at the smoke dome side, front and rear walls to see that they are aligning correctly and that the surfaces are smooth and uniform.

Make sure connections are covered with an adequate amount of mortar. Remember that you have the option of using shims but they must be removed and any holes filled. Make any adjustments to the fireplace alignment before continuing to the next step.

12. Assemble Upper Dome (TFS/OFS 33-10) and Dome Sides (TFS/OFS 33-8) as shown in **Figure 33**. Check your assembly here. If things are proceeding as they should be, the finished top surface should be flat and level.

13. Finally, set the Dome Top into position. Be sure that it is flush in every direction as you place it on the crest of the smoke dome wall assembly. After this is done, proceed to section on "Installing Damper and Chimney System" on **page 26**.

Note: The chimney hole on the Dome Top is not centered from front to back - it should be offset closest to the rear of the fireplace (see **Figure 33**).

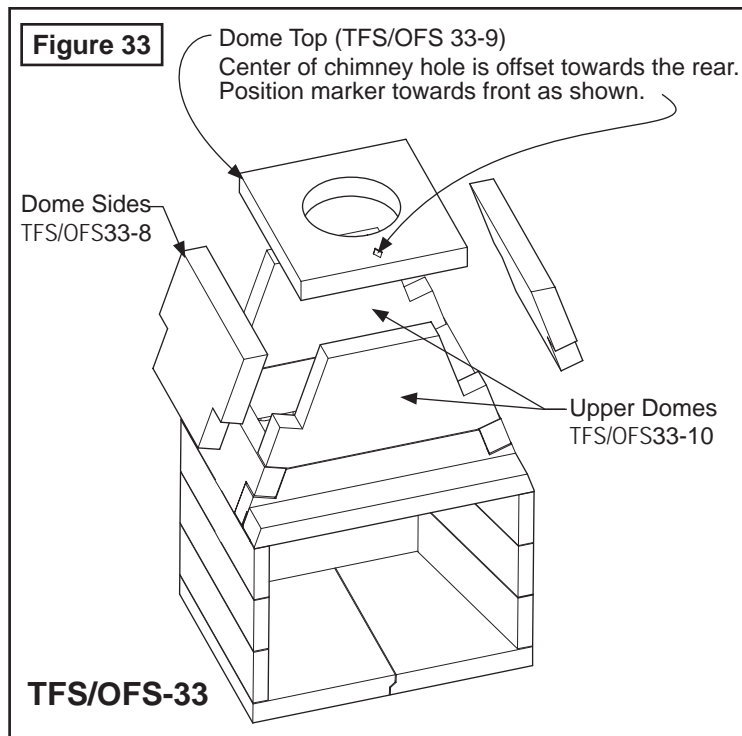

14. **TFS/OFS-39/44/49:** After the third row of firebox is complete, place #3 rebar (8 each, 36 inch long) vertically through the cells until they reach bottom. Position them adjacent to the rebar or all-thread sticking up from the hearth as shown in Figure 34.

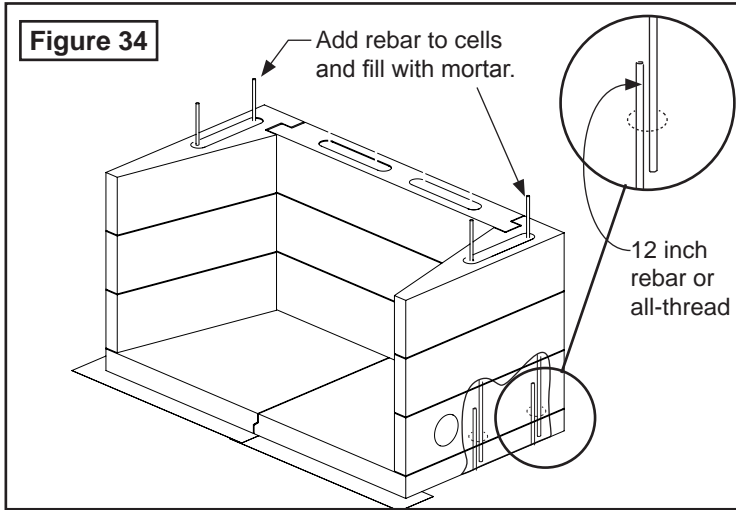

15. Install Downdraft Diverter and final row of Side Walls (Fig.35). All components must be level. Mix approx. 2 cu. ft. of Ready-Mix Concrete. Insert 28" rebar vertically through the cells, into the holes in the hearth, adjacent to the rebar and/or all-thread sticking up from the hearth. Fill all cells with Ready-Mix Concrete mix.

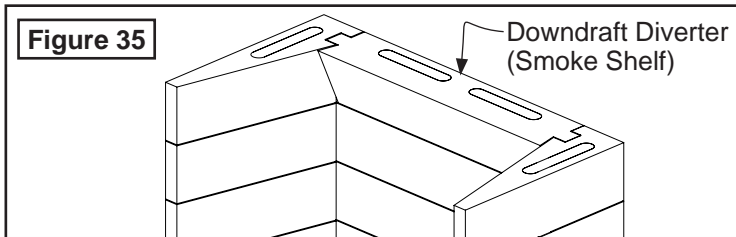

16. Set the Lintel, T-Bar, Lintel Front and Lower Rear Dome as shown in **Figure 36**. Check that all is level. If adjustments are needed, use shims and fill gaps with an appropriate amount of mortar. **Note:** Although you are cautioned to use Burntech® mortar sparingly because it does have such holding power, you should look over the firebox assembly at the end and fill in any gaps, especially joint connections, with the mortar. **Important:** Adjustments can only be made while the mortar is still wet when correcting for squareness and leveling.

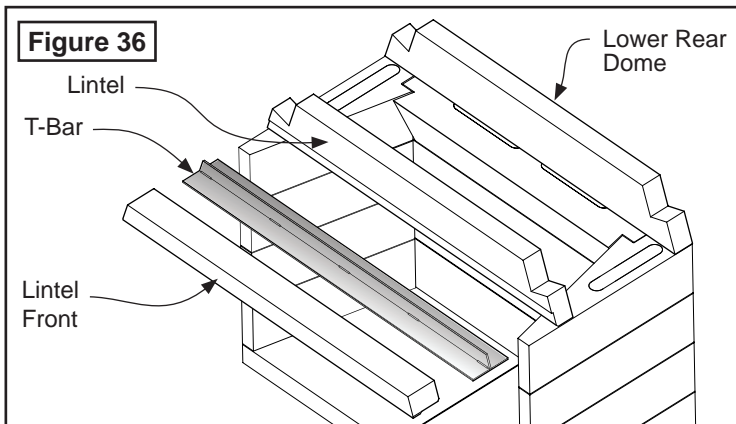

17. Assemble Lower Dome Sides as shown in **Figure 37**. The beveled face lines up with the inward angles of the lintel sides. Resulting top surfaces should be level.

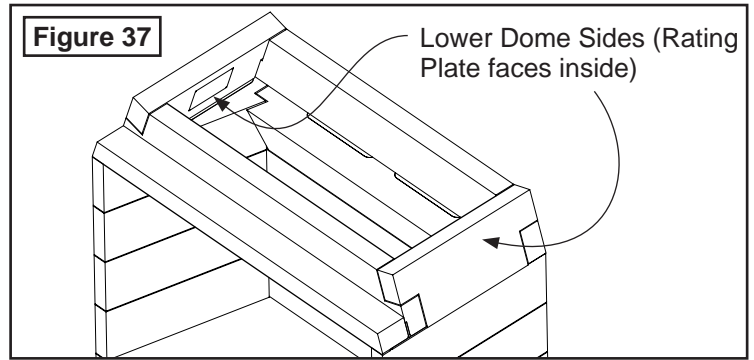

18. Verify that the Smoke Dome side, front and rear walls are aligning correctly and that mating surfaces are smooth and uniform. Make sure connections are covered with an adequate amount of mortar. Remember that you have the option of using shims but they must be removed and any holes filled. Make any adjustments to the fireplace alignment before continuing to the next step.

19. Assemble Upper Dome and Dome Sides as shown in **Figure 38**. The top surfaces of all dome parts should be flat and level.

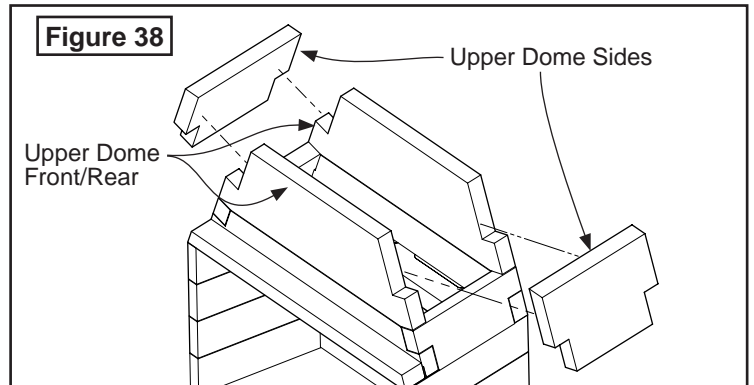

20. Finally, set the Dome Top into position. Be sure that it is flush in every direction as you place it on the crest of the smoke dome wall assembly.

Note: The chimney hole on the Dome Top is not centered from front to back - it should be offset closest to the rear of the fireplace (see **Figure 39**).

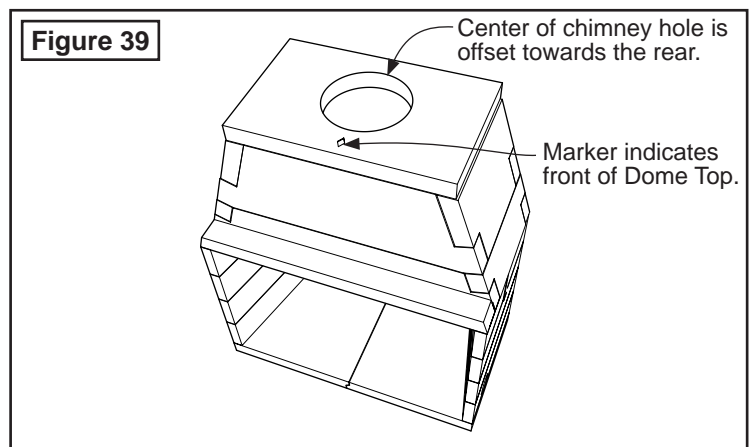

TFS-63 Assembly Instructions:

21. Place the Burntech® Fireplace hearth base on top of your concrete floor or metal base. For concrete slabs, supporting floor needs to be rated at ASTM 90.
22. a) **Combustible Floor Installations:** Mix a batch of mortar and adhere hearth slabs to the cement board (see Figure 24, Pg.18). All-thread rods should stick up through the holes on the hearth slabs.
 b) **Non-combustible Floor Installations** (TFS Models Only): Draw an outline footprint 67" x 28" for the TFS/OFS-63 footprint and mark the centers for the rebar locations using the hearth slabs as templates. Drill holes for rebar 4 inches into the concrete slab and secure the 10 pieces of 12" long rebar with epoxy.

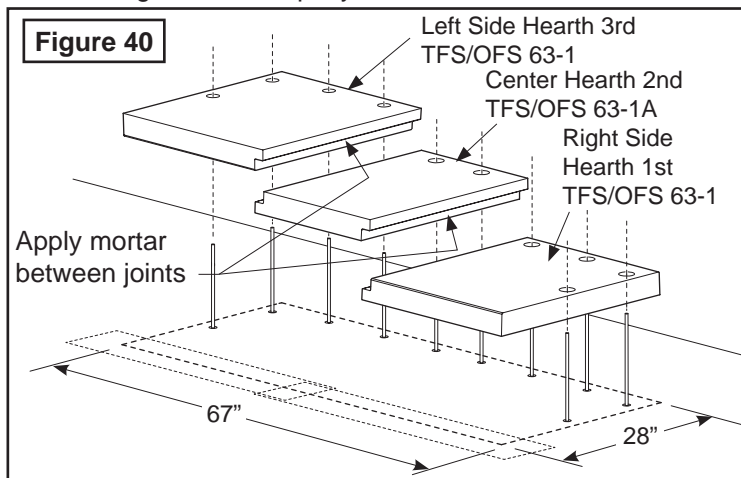

23. Mix a batch of mortar and prepare bottom surface of Right Side Hearth to be bonded (Figure 41), then lower the piece into place on the outline created before. Align lower Right Side Hearth on the outline created. The 67" width dimension allows for an approximate gap of 1/8" between slabs for the additional mortar to unite the remaining slabs. Continue process for remaining hearth sections while moistening and adding mortar between joints at slab ends.

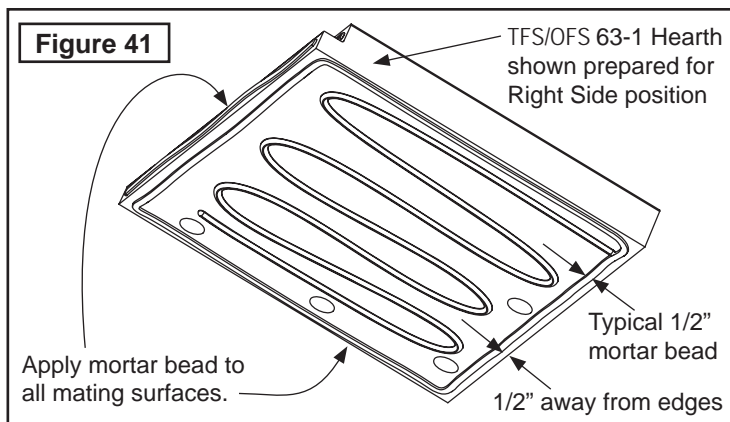

24. Apply mortar in like manner to the Center Hearth and place next to the Right Side Hearth. Check that surface is LEVEL and use shims if necessary.
25. Apply mortar to the remaining Hearth except this time apply beading on surface to be facing floor as shown in Figure 42.

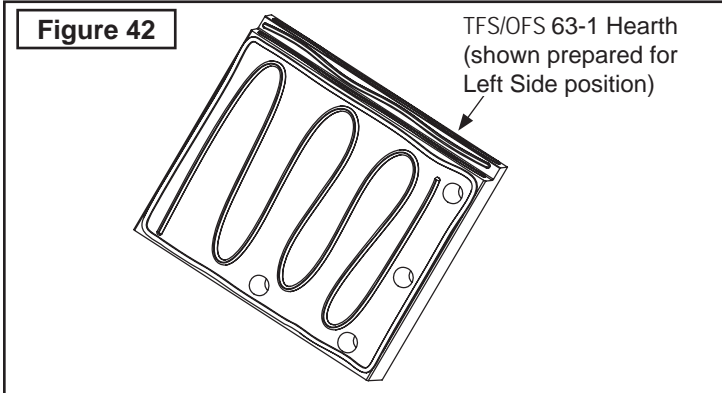

26. Before installing side walls, confirm placement of outside combustion air access (if required), this can be installed either side depending on which side is accessible to outside combustion air (all diagrams in this manual show the combustion air inlet hole on the right side).

27. Prepare side wall mating surfaces with the prepared mortar as shown in Figure 43.

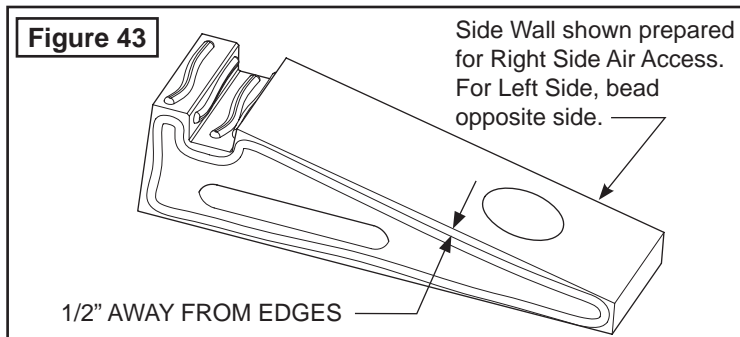

28. Keep the assembly of the next sections of the firebox side walls moving up (Figure 44), keeping components moist, mixing mortar as you need it and threading the mortar appropriately as you stack each section, one onto the next. Constantly check for squareness and levelness while building each course of block. As you complete each section, make certain that you adhere the mortar at every joint.

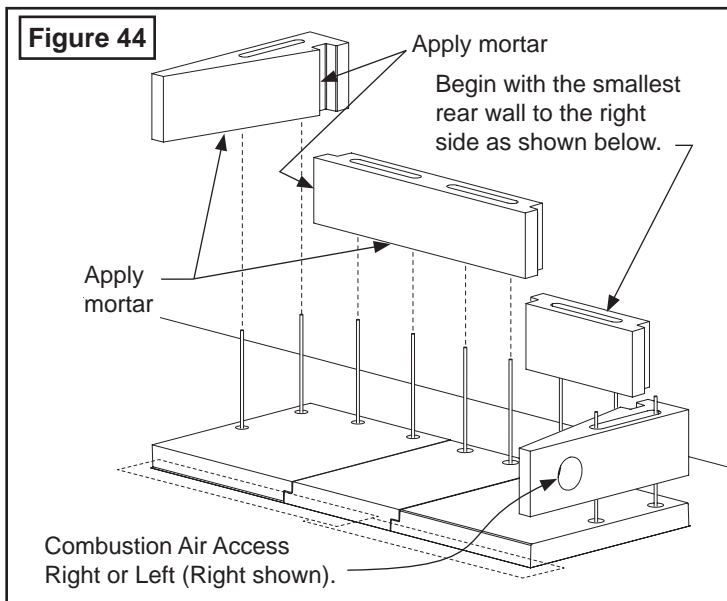

22. Rear walls are staggered on every row as shown in Figures 45 and 46.

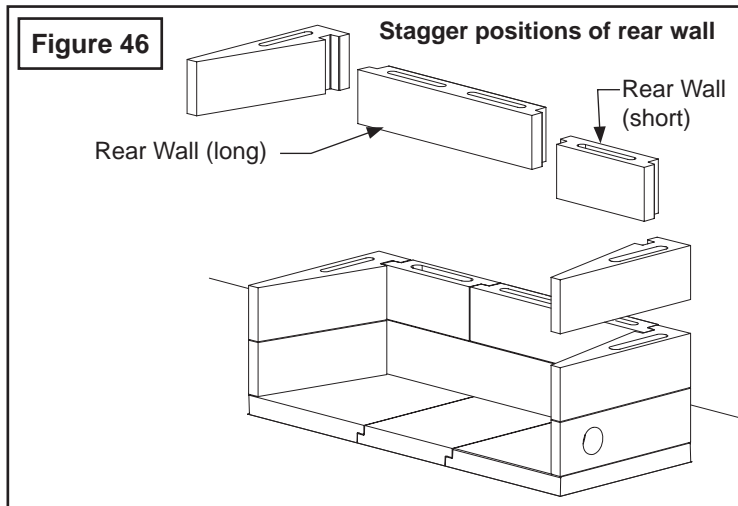
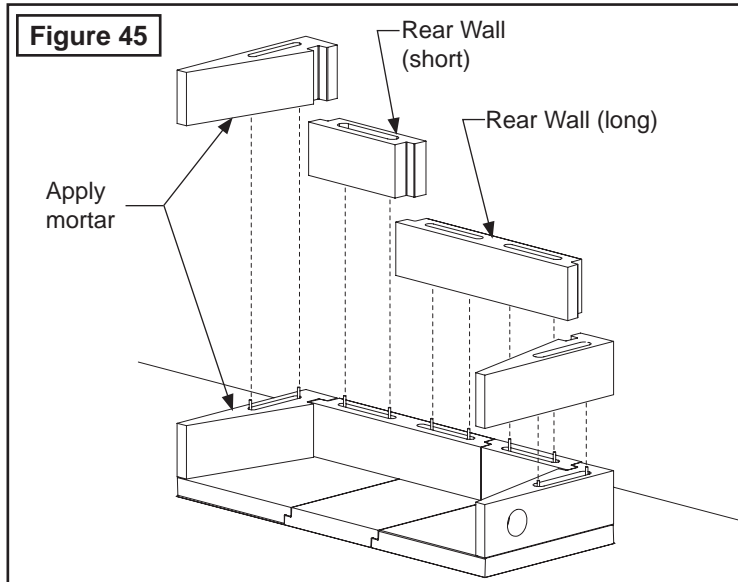

23. After the third row of firebox is complete, install Downdraft Diverter sections (TFS63-4) as shown in Figure 47.

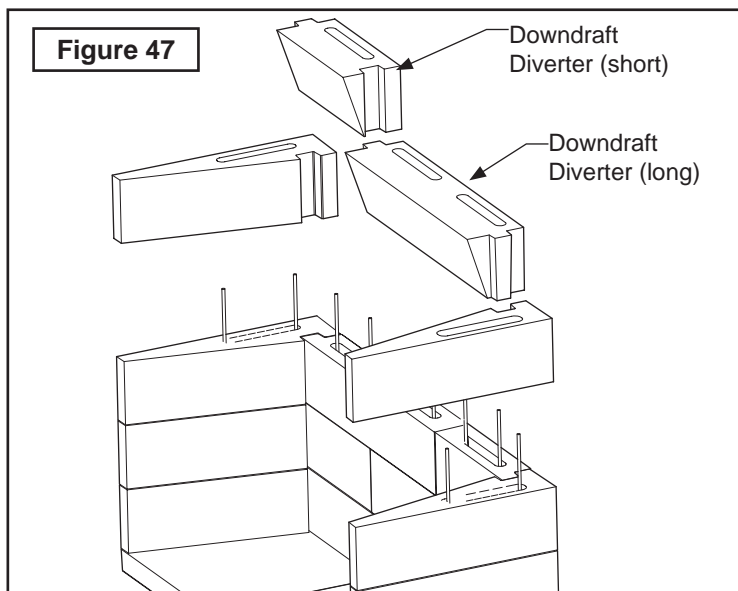

31. After the last side walls are installed, place #3 rebar (10 each, 36 inch long) vertically through the cells, into the holes in the hearth, adjacent to the rebar and/or all-thread sticking up from the hearth and fill all cells with Ready-Mix concrete mix.

32. Set the Lintel and Lower Rear Dome in place as shown in Figure 48. Check that all is level. If you need to make adjustments, use shims between the lowest wall component and the top surface of the base plate. Once leveled, fill any resulting gaps with mortar.

Important: Adjustments can only be made while the mortar is still wet when correcting for squareness and leveling.

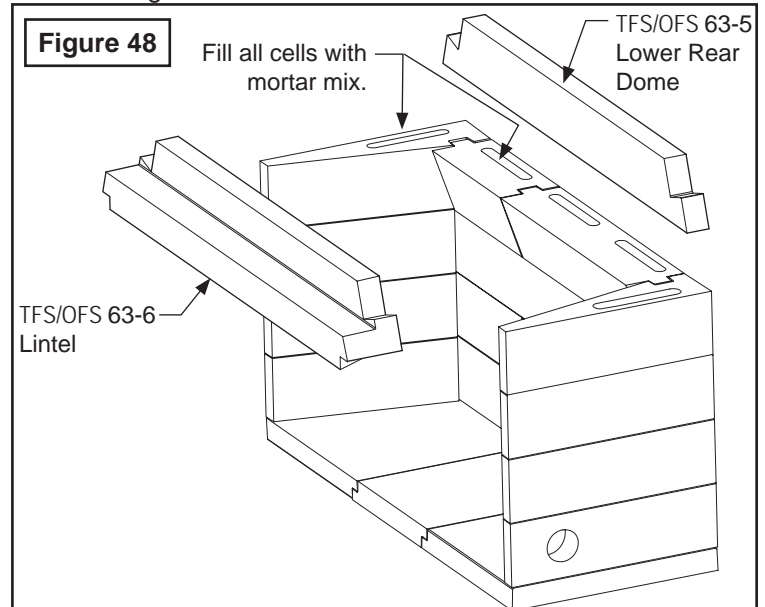

33. Assemble Dome Sides (TFS/OFS 63-7) as shown in Figure 49. The beveled face lines up with the inward angles of the lintel sides. Top surfaces should be level.

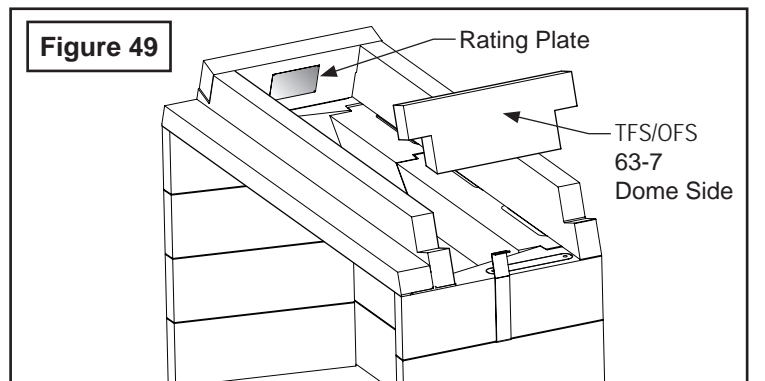

34. Position Middle Domes (TFS/OFS 63-10) so that outer faces are flush to the lower dome as shown in Figure 50.

35. Carefully install Dome Middle Sides (TFS/OFS 63-8) as shown in Figure 50.

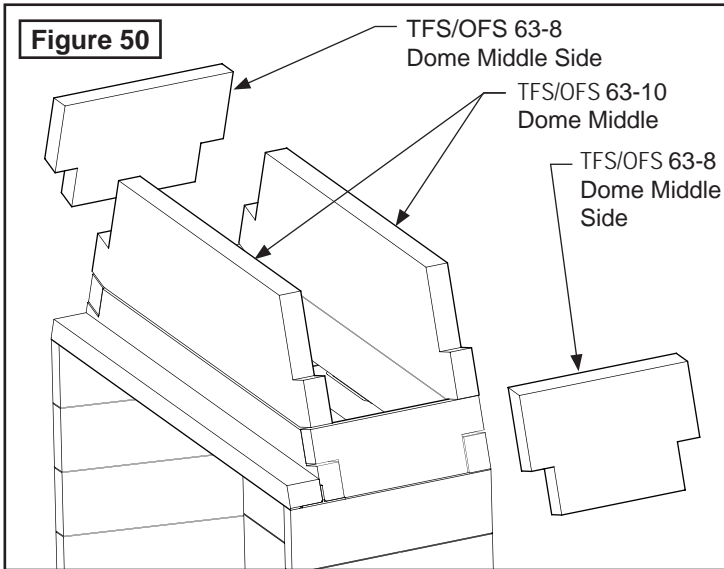

36. As you are connecting each Burntech® component, be certain you are following the instructions given previously for using Burntech® mortar. Stop to look at the smoke dome side, front and rear walls to see that they are aligning correctly and that the surfaces are smooth and uniform. Make sure connections are covered with an adequate amount of mortar. Remember that you have the option of using shims but they must be removed and any holes filled. Make any adjustments to the fireplace alignment before continuing to the next step.
37. Assemble Upper Domes (TFS/OFS 63-11) and Dome Sides (TFS/OFS 63-7) as shown in **Figure 51**. Check your assembly here. If things are proceeding as they should be, the finished top surface should be flat and level.

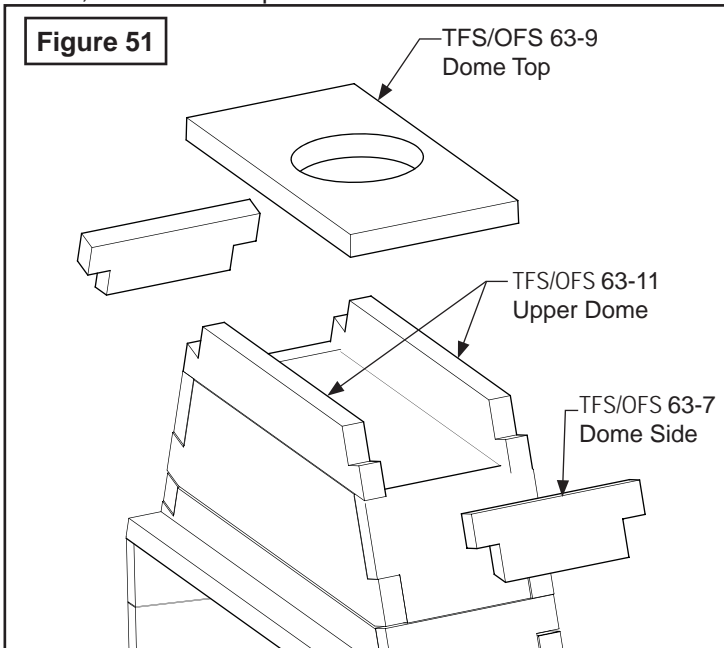

38. Finally, set the Dome Top (TFS/OFS 63-9) into position. Be sure that it is flush in every direction as you place it on the crest of the smoke dome wall assembly.

Note that the chimney hole on the Dome Top is not centered from front to back - it should be offset closest to the rear of the fireplace. A marker on the Dome Top indicates the front (see Figure 52).

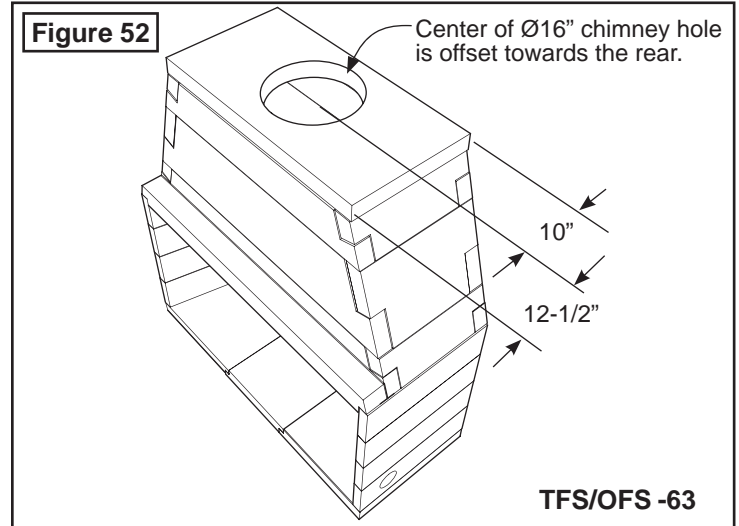

39. Now that you have completed the smoke dome assembly, all the components should stack up for a smooth transition into the flue components. Setting the smoke dome completes the Burntech® Firebox and Smoke Dome assembly. You are now ready to begin the installation of the necessary fire brick lining and the flue components.

WARNING: DO NOT PACK REQUIRED AIR SPACES WITH INSULATION OR OTHER MATERIALS.

40. For use of Masonry Chimney sections on the Burntech® fireplaces, please see Masonry Chimney instructions located online at www.Burntech.com

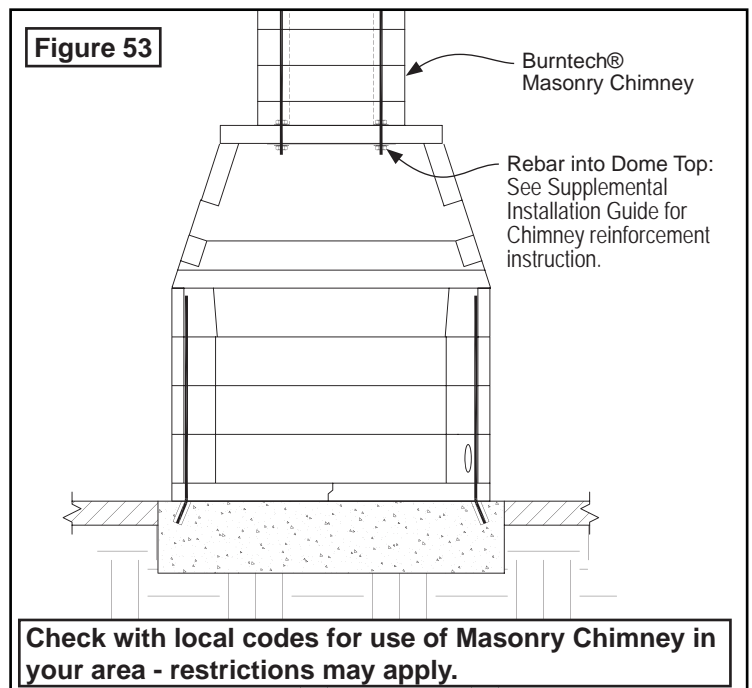

Check with local codes for use of Masonry Chimney in your area - restrictions may apply.

OFS Installing Damper and Chimney System

Dampers may not be required on Outdoor Fireplaces, consult with your local Building Department. Refer to Page 14 of this manual for specific approved chimney requirements before proceeding.

All chimney systems (Sold Separately by Burntech®) must be installed with an integrated Damper System / Anchor Plate installed on or in the fireplace. Installers are cautioned to put the chimney system together exactly as instructed and shown in chimney manufacturer's guide. Any modifications may have serious consequences resulting in an accident or malfunction. If instructions are not followed, the warranty on the product will become null and void.

Top Mounted Damper System / Anchor Plate:

1. Apply a 1/4" bead of gasket cement around the base of the Anchor Plate as shown in **Figure 54**. Apply a 1" thick ceramic fiber blanket to the gasket cement.

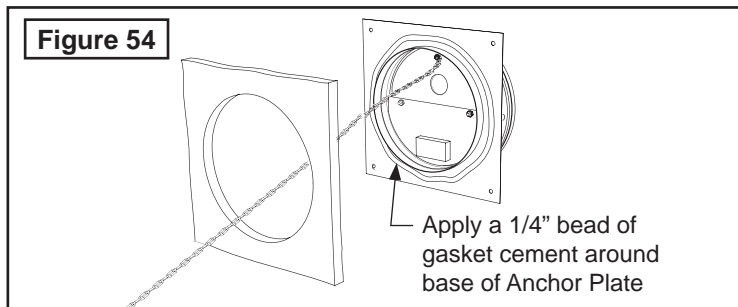

2. Apply balance of gasket cement in a 1/4" bead on top of smoke dome approx. 1-1/2" around periphery of chimney hole. Install damper assembly on top of unit pressing damper and insulation blanket into cement. Secure with four 1/4" X 1-14" masonry fastener.

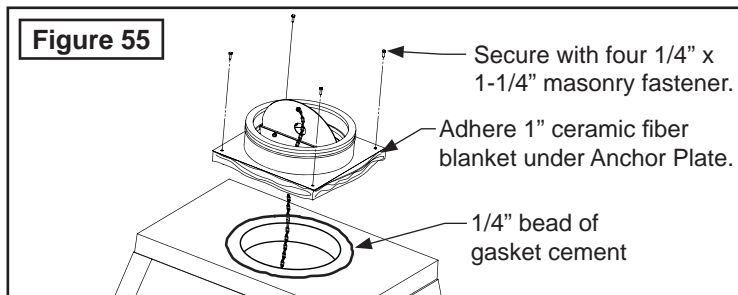

3. Place chimney adapter onto top of damper plate and center in opening using gasket supplied with adapter.
4. Attach adapter with screws supplied by carefully drilling holes into damper plate.
5. Attach damper chain stop on center rear of lintel 3" vertical from opening using (3) #8 cement fasteners.

Traditional Steel Damper Option:

Requires a Burntech® Steel Damper and Damper Blocks (Sold Separately. Refer to the products list at the back of your Manual for the properly sized Damper and Damper Blocks for your specific model)

1. Install properly sized Burntech® Damper Blocks as shown in Figure 56.
2. Install a properly sized Burntech® Damper Plate (sold separately) per manufacturer's instructions.

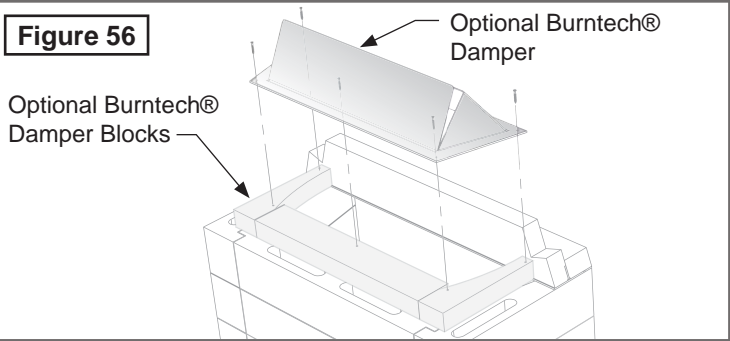

3. Pre-drill Damper with 1/4" steel bit at the locations shown in Figure 56.
4. Pre-drill Damper blocks with 3/16" masonry drill bit. Drill the hole 1 1/4 Inches deep.
5. Install (5) 1/4 inch by 1 1/4 inch long masonry screws (sold separately). **LIGHTLY TIGHTEN SCREWS UNTIL THEY ARE SNUG. OVER TIGHTENING WILL RESULT IN A BROKEN DAMPER BLOCK**

Attention: Clearance to combustible construction cannot be reduced during course of construction. For the safe operation of the finished fireplace, these clearances must be followed when building the framework for the chimney system.

Note that the most important aspect of the installation is maintaining the minimum required clearances to combustible materials according to the chimney pipe manufacturer's recommendations, otherwise a potential fire hazard may occur.

Warning: do not interchange chimney manufacturer's parts with any other parts except those specifically required by the chimney manufacturer's recommendations otherwise a potential hazardous condition may be created.

Attention: When choosing a Chimney System it must meet the following requirements:

Designed for installation in accordance with the National Fire Protection Standard and UL 103.

Meets the requirements of NFPA 211.

Designed in accordance with ICC Codes.

Optional:

Assuming you have sections of vertical pipe that are more than 10' (ten feet) measuring between elbows, you must insert – at midpoint – a chimney stabilizer. When installing the stabilizer, pull out the support straps with a good amount of tension and hammer to the frame.

Please refer to the approved chimney pipe manufacturers' installation instructions.

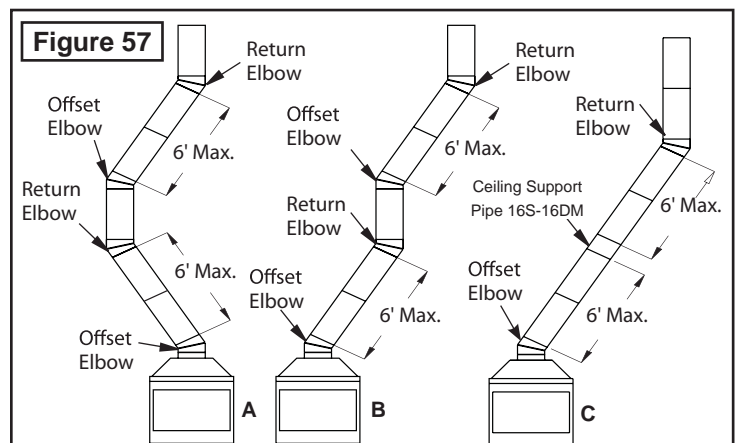



Firestop Radiation Shield

A Firestop Radiation Shield is required in multi-story fireplace installations at each floor penetration above that where the Support Box is located. They may also be required for outdoor fireplaces contained within a framed structure. Check with your local building department for requirements. Firestop Radiation Shield is required in multi-story installations at each floor penetration above that where the Support Box is located (Figure 58).

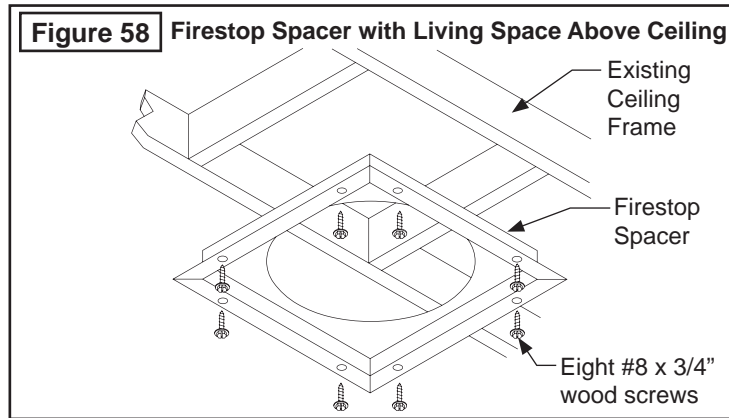

Firestop Radiation Shields also provide complete separation from one floor space to another or attic space as required by most codes. When the double wall pipe passes through a framed opening into an attic space, the Firestop must be placed into an attic floor as shown in Figure 59.

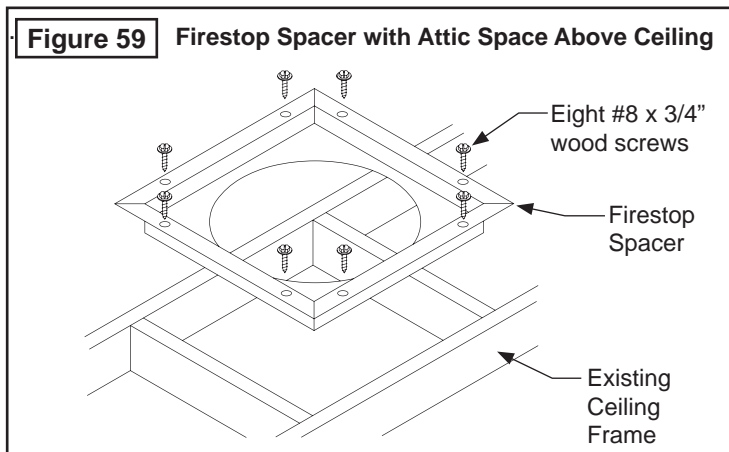

Follow your chimney manufacturer's instructions on specific guidelines pertaining to their chimney and Firestop Radiation Shield installation instructions.



Firebrick Installation Instructions

Firebrick (sold separately) are required to complete your Burntech® Fireplace Installation. Failure to install firebrick may cause immediate hazard, property damage or loss of life and will void all liabilities to the manufacturer and will void all warranties explicit or implied.

Firebrick Options

- Burntech® MODULAR FIREBOX KITS are available in Herringbone and Running Bond Patterns (see figures 61 and 62) as well as color options. Refer to your Product list at the back of your manual for proper sizing and patterns.
- STANDARD MASONRY FIREBRICK may also be used instead of Burntech® MODULAR FIREBOX KITS. Please

consult with your local masonry supply yard for approved firebrick.

- Firebrick thickness must be a minimum of 1 1/8" thick and shall only be applied with Burntech® Mortar. Do not leave any voids or gaps behind the firebrick or doing so may result in the brick falling off when exposed to high temperatures.
- To ensure a good bond between the firebrick and the Burntech® FIREPLACE, use a damp sponge to moisten the firebrick and the Burntech® FIREPLACE prior to installation of brick. Some installers have found it be beneficial to place a 1/16"-1/8" skim coat of Burntech® Mortar over the inside of the Burntech® FIREPLACE firebox area prior to installation of brick as well as parge coat the Firebrick before it is laid to ensure a strong bond between the Modular components and the Firebrick.
- Burntech® Mortar shall be used as the adhesive and as the grout between the firebrick. The grout joints between the firebrick shall be no more than 3/16" wide.
- It is recommended that you use a licensed Masonry Contractor to lay the brick to ensure a quality finish. Your contractor may need to drill for gas, electrical or combustion air kit access holes. Be sure to patch around these holes with Burntech® mortar.
- Make sure the fireplace is installed with the finished firebrick floor of the fireplace so that it is at least 11" (eleven inches) above the combustible floor system.
- Disclaimer: Burntech® Fireplace Solutions wishes to express that as the manufacturer of Burntech® Fireplaces, they cannot take any liability or responsibility for the way the firebrick or the firebrick mortar performs. It is not unusual in the course of the life of the firebrick, or the firebrick mortar, for heat stress cracks to appear. Burntech® Fireplace Solutions cannot be responsible for this and other wear and tear to the firebrick and mortar.

Modular Firebrick Lining

If using our Burntech® Firebrick Liners, simply use an extra bag of the mortar we supply. Install Hearth Liner first, rear next and sides last. Consider if brackets for grates will be required also if pre-drilling is required for gaslines, electrical or if the outside combustion air kit is to be installed. The rear Liner Panel is straight from the bottom to the top front edge of the Downdraft Diverter edge. The space behind does not have to be filled (Figure 60).

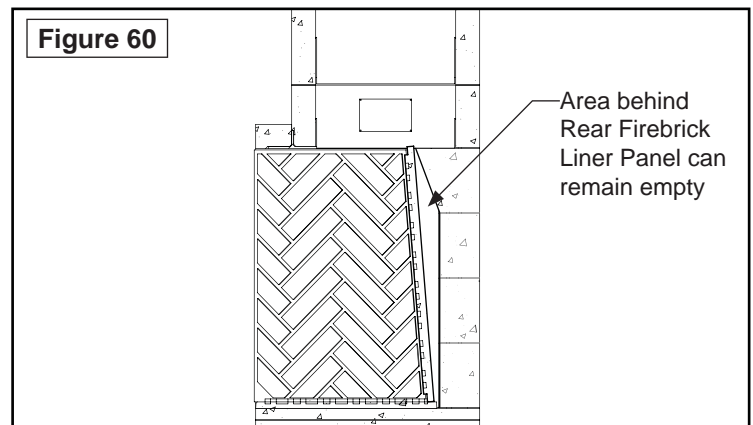

The following Firebrick Patterns are available from Burntech® Fireplace Solutions:

FBK(XX)HB- Herringbone

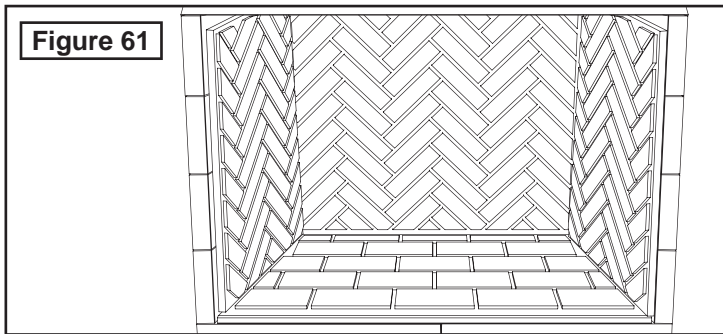

FBK(XX)RB- Running Bond

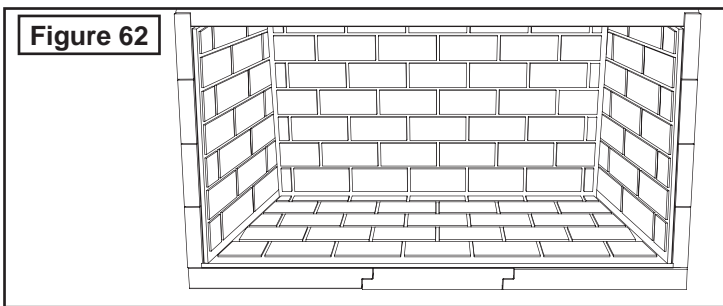

Fireplace Finishes & Combustible Trim Clearances

Hearth Material & Dimensions – Strict codes control the types of materials that you can select for your Burntech® Fireplace's hearth as well as the hearth's length and width. All hearth extensions must be made of code-rated, noncombustible materials such as tile, brick, concrete or stone. Refer to pages 11-12 for more information.

As with any radiant heat fireplace, all Burntech® Fireplaces must comply with building code safety clearances, per units that have openings of 6 sq. ft. (six square feet) or greater. For Mantel clearances see **Figure 17**. Walls that Adjoin – Safety codes and all practical outlooks insist that your fireplace cannot be installed closer than 2 ft. (two feet) to any walls in the room the fireplace is housed in or to any walls of adjoining rooms.

Caution in Regards to Combustibles – If any part of the fireplace or objects in the room (curtains, rugs, paint, cushions, etc.) start to show warping or discoloration due to heat from the fireplace, it is time to take immediate action. Do not use the fireplace until you have figured out how to address the problem. You are facing a potential fire hazard. Burntech® Fireplace Solutions cannot be responsible for the make-up of material on the exterior of the fireplace you have chosen, nor can Burntech® Fireplace Solutions be held responsible for the materials in a room that may be responding negatively to heat. However, in almost all cases, there is a solution to the problem, either by making adjustments to airflow or the modifications to the room itself.

Installing Outside Air *

*Outside Air kits may not be required on outdoor fireplaces. Consult with your local building department.

The Burntech® Fireplace needs enough replacement air to function properly and some local building codes may require outside combustion air to be provided. If no replacement air is provided, improper flue drafting may occur, creating negative pressure whereby smoke may enter the home, especially in homes that are very well insulated and tightly sealed. Check local building codes for specific requirements.

Install Combustion Air Kit BFP4AK into the Burntech® Firebox through the side wall opening provided. A 4" dia. hole will also be required through the firebrick side lining (see **Figure 63**). The tubing that goes out of the firebox wall must feed into a flexible metal conduit as the source for outside combustible air. It can go straight out through an outside wall or into a ventilated crawl space. If crawl space is used, check codes for proper termination.

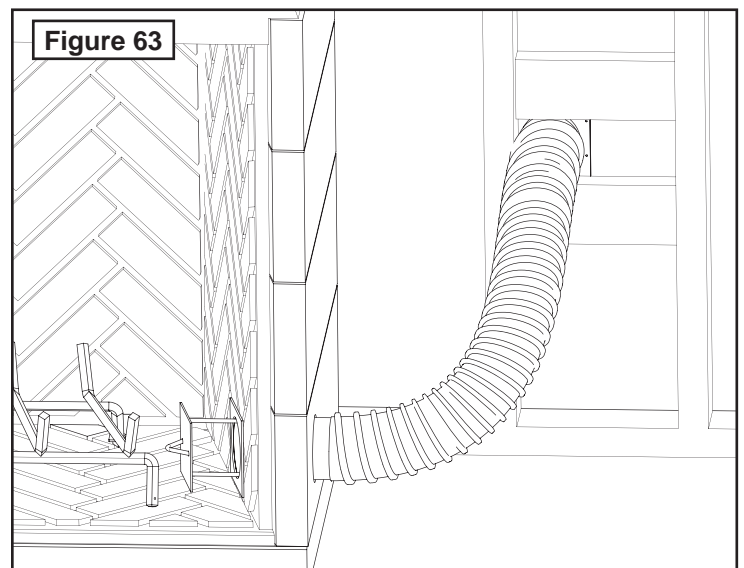

Be sure that you carefully check the source of the outside air before you choose the site for your air intake. You don't want a place where snow will collect, where bushes or trees will be growing or a location that is too close to any other structure.



Adding a Gas Pipe

You may elect to add a vented decorative gas appliance (gas log) to your Burntech® Fireplace. If so, follow the installation instructions from the Decorative Gas Appliance manufacturer. Familiarize yourself with requirements for installation as outlined by the National Fuel Gas Code, ANSI Z223.1. This gas pipe provision should only be used on a decorative gas appliance.

You can route the gas piping in the firebox side walls. Use a drill with a masonry bit. Follow all building codes when running your gas line.

Fill in the holes you have drilled around the gas piping with the regular Burntech® mortar.

Follow the Gas Log manufacturer's instructions.

OFS Adding Electrical Connections

Certain Gas Logs require power. Electrical feed lines can be run through the floor, back wall, or side walls with the fire-resistant sheathing provided by the log manufacturer. Be sure to follow log manufacturers instructions as well as local building and electrical code requirements.

OFS Fireplace Grates and Screens

To complete your fireplace installation, a fireplace grate will be required for safe operation. The fireplace grate can be obtained from Burntech® Fireplace Solutions or if choosing an alternate, it must be sized to 50% of the hearth maximum. Additionally, a fireplace screen must be installed for safety.

When ordering, please refer to the parts lists in the beginning of this manual.

Fireplace Door Accessory

Doors may not be required on outdoor fireplaces. Consult with your local building department.

WARNING: Never touch fireplace doors during operation of fireplace or while the glass is hot. Touching the glass will result in serious injury.

IMPORTANT: Only Crown-Breckinridge or McKenzie-Pendelton Doors are approved for use with this fireplace. For installation Instructions, see separate instructions included with doors.

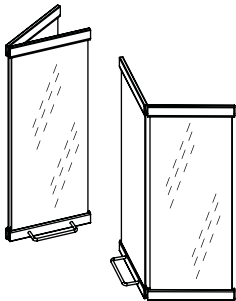

OFS Burntech® Owner's Operation & Precautions

Installers of the Burntech® are urged to leave the owner's manual with the unit after installation is complete.

WARNING: Do not attempt to operate your fireplace without a fire safety screen installed.

CAUTION: The manufacturer cautions against using chemical chimney cleaners. Never use charcoal or coal in the fireplace under any circumstances.

First Lighting – After construction is completed, all elements of the fireplace and chimney system must be completely dry. This means that the unit must stand without any firing for a minimum of 28 days. Only after that period of time can a first lighting take place. The first fire must be small and well-controlled, started with a small amount of kindling. Add no more than eight pounds of wood, preferably small logs not more than 3" (three inches) in diameter. You will probably burn no more than three to four of these small logs. Do not let the fire burn for more than one hour. After this first lighting – when the fireplace has started to "cure" Do not set another fire for at least 24 hours.

Second Lighting – Start the fire slowly and gradually as you did with the first lighting, but this time you can burn up to ten pounds of firewood, probably four to five logs that are 3" (three inches) in diameter. With the second lighting you can let the fire burn two hours – no more.

After First and Second Lighting – When the fireplace has been properly cured with 1st and 2nd lighting, you will be able to add a full fuel load to the Burntech® which is about 10 to 15 pounds of firewood at any given time. Consider that this typical fuel load is three to four dry hardwood logs that are about 6" (six inches) to 8" (eight inches) in diameter.

Without a grate for your firewood to rest on, you cannot get the air flow you need under the fire which makes for a hotter, more satisfying fire.

Don't "over burn" – Always remember, your Burntech® Fireplace is an elegant addition to your home. It is not an indoor incinerator! If you start to use the fireplace and begin a routine of "over burning," you can permanently and unalterably damage the unit.

WARNING: DO NOT burn household trash, chemicals and combustibles, cardboard boxes, document papers, scrap lumber or stray branches from your yard, particularly pine. Burning any of these materials will cause an unsafe condition and will void your warranty!



Starting a Fire and Basic Operation

Before starting a fire in your fireplace, open the damper to its' fully open position. Crumple some paper and place it on the log grate. Use some soft, dry wood as kindling and put it on top of the paper. Place some small logs or split logs atop the paper and kindling. Top your fuel load with a couple of hardwood logs or split logs (Oak or Hickory). Make sure you stack the logs so they fall inside the grate as they burn.

Note: To get the most out of your wood, it is recommended that you let it set and completely dry out for nine months to a year.

When you are satisfied with the arrangement of your wood load, light the paper which in turn will ignite the kindling, then the softer wood and finally, the harder wood logs. As the fire burns, you can carefully lay additional logs on the flame, but make sure you place them gently without forcing them into the opening.



Annual Fireplace Maintenance

Your Burntech® fireplace and chimney require seasonal and monthly maintenance.

It is recommended that inspection of the fireplace and chimney take place on a monthly basis during the heating season. Start at the top, looking for birds' nests, leaves or any other obstructions. Also check the spark arrestor, for creosote or soot build-up.

A Professional Chimney Sweep may be hired to clean the firebox and chimney at least twice a year. If doing it yourself, use a plastic, wood or steel brush for the inside of the chimney.

For the spark arrestor, scrub with a wire brush. To dismantle the chimney cap for cleaning of the flue, unscrew the four screws that hold it in place. For cleaning access from below, open the damper in the firebox. It is best to use a flexible handle chimney cleaning brush made especially for the job.

If your fireplace system has any offset chimney sections, start cleaning with the flexible brush from the top of the section downward to the elbow. Then clean from the firebox up to the offset/return section.

Make sure to cover the floor of the fireplace and out to the hearth with a damp sheet that has been taped securely in place. When all the soot has settled, remove the sheet and vacuum up. Don't sweep the excess soot!

Never use any chemical cleaners when cleaning the chimney system since their residue may cause a fire hazard.

During heating season as you conduct your monthly inspection of the firebox and chimney, be sure to also check the outside of the chimney, metal flashing and weather seals that surround it. If you find any cracks or openings around screws or nails, seal them to avoid any roof or chimney chase leaks.

SURFACE CRACKS

Burntech® fireplaces are manufactured using high quality materials. During the drying process though, surface cracking may occur. These small cracks (under 1/16" will not affect the fireplace safety or performance). During the assembly process, fill surface cracks with thin-set mortar and brush when drying for a smooth surface finish.

REMOVAL OF CREOSOTE AND SOOT FORMATION

Creosote vapors are known to form in the relatively cool chimney flues of slow burning fires, hence, creosote residue collects on the flue lining. Because of soot and creosote build-up, it is recommended that the fireplace and chimney cleaning be done twice a year. In colder climates, cleaning should be done more often.

Before performing maintenance on your fireplace make sure you shut off gas and electrical connections and allow the fireplace to cool completely.

Use only solid fuel in your fireplace. You may use a natural or LP gas log lighter as a method to start your wood fire.

The Chimney Damper must be in the OPEN position whenever there is heat in the fireplace.

Customer Service & Parts Replacement

Most parts and accessories may be purchased from your dealer. For additional Parts and accessories please call Burntech® Fireplace Solutions Monday thru Friday 9 AM to 4 PM (Pacific Standard Time) at (818) 564-4253 or Fax your order to (818) 564-4232. You may also visit our website at: WWW.BURNTECH.COM

Appendix I

For installations regulated by the International Residential Code, the support foundation for the fireplace installed on concrete shall consist of a minimum of 6 inches thick reinforced concrete slab. The minimum specified compressive strength of f'_c , shall be as required in Table R402.2 of the International Residential Code (IRC). Concrete subject to moderate or severe weathering as indicated in Figure R301.2(3) of the International Residential Code (IRC) shall be air entrained as specified in Table R402.2 of the International Residential Code (IRC). The maximum weight of fly ash, other pozzolans, silica fume, slag or blended cements that is included in concrete mixtures for garage floor slabs and for exterior porches, carport slabs and steps that will be exposed to deicing chemicals shall not exceed the percentages of the total weight of cementitious materials specified in Section 4.2.3 of ACI 318. Materials used to produce concrete and testing thereof shall comply with the applicable standards listed in Chapter 3 of ACI 318.

For installations regulated by the International Building Code (IBC), the support foundation for the fireplace installed on concrete shall consist of a minimum of 6 inches thick reinforced concrete slab. The concrete strength and durability shall comply with Sections 1903, 1904 and 1905 of the International Building Code (IBC).

TABLE R402.2 MINIMUM SPECIFIED COMPRESSIVE STRENGTH OF CONCRETE

TYPE OR LOCATION OF CONCRETE CONSTRUCTION	MINIMUM SPECIFIED COMPRESSIVE STRENGTH^a (f'_c)	
	Negligible	Moderate
Basement walls, foundations and other concrete not exposed to the weather	2,500	2,500
Basement slabs and interior slabs on grade, except garage floor slabs	2,500	2,500
Basement walls, foundation walls, exterior walls and other vertical concrete work exposed to the weather	2,500	3,000 ^d
Porches, carport slabs and steps exposed to the weather, and garage floor slabs	2,500	3,000 ^{d,e,f}

- a. Strength at 28 days psi.
- b. See Figure R301.2(3) for weathering potential.
- c. Concrete in these locations that may be subject to freezing and thawing during construction shall be air-entrained concrete in accordance with Footnote d.
- d. Concrete shall be air-entrained. Total air content (percent by volume of concrete) shall be not less than 5 percent or more than 7 percent.
- e. See Section R402.2 for maximum cementitious materials content.
- f. For garage floors with a steel troweled finish, reduction of the total air content (percent by volume of concrete) to not less than 3 percent is permitted if the specified compressive strength of the concrete is increased to not less than 4,000 psi.

Appendix II

FIGURE R301.2(3) WEATHERING PROBABILITY MAP FOR CONCRETE

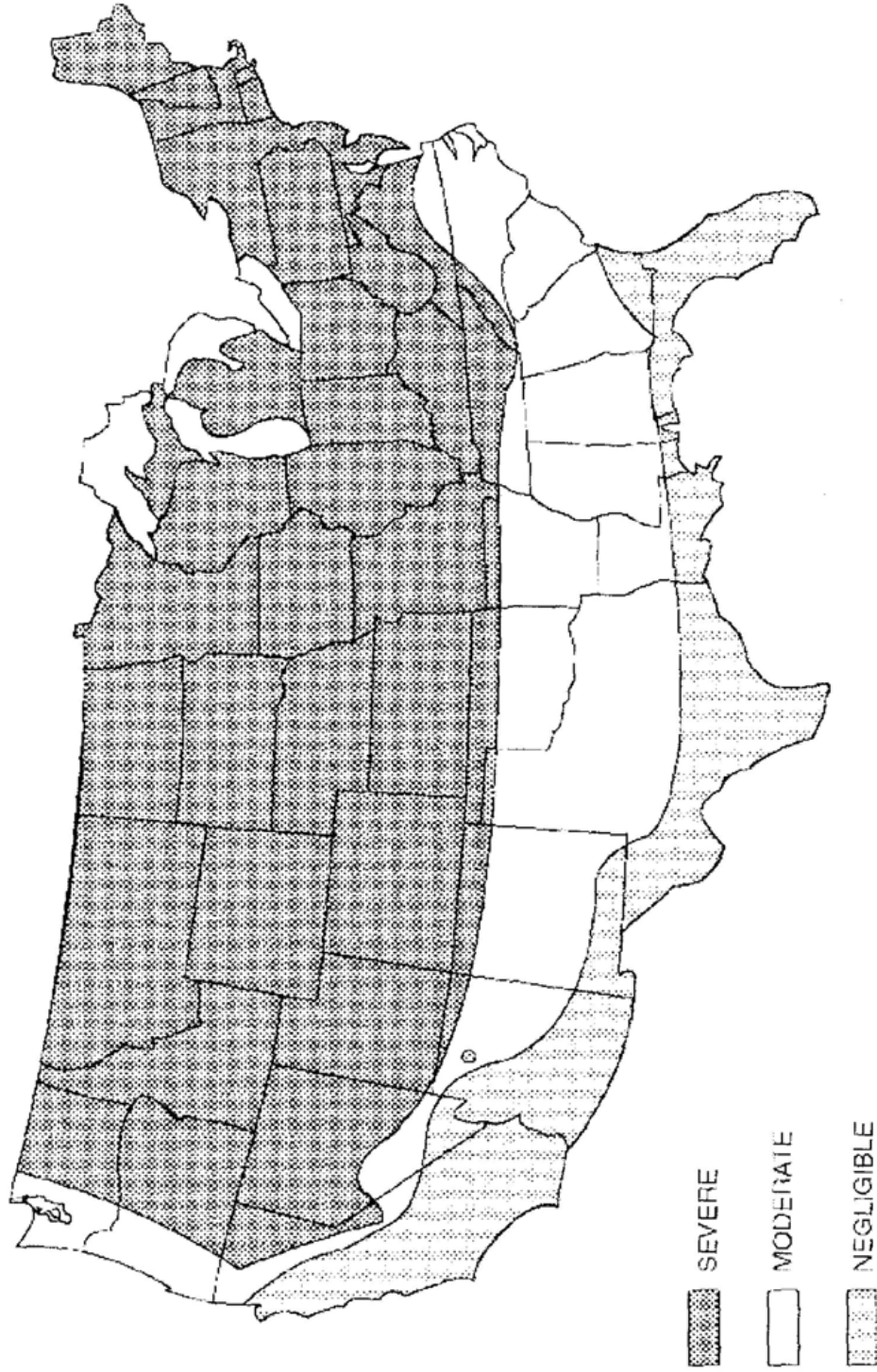

- a. Alaska and Hawaii are classified as severe and negligible, respectively.
- b. Lines defining areas are approximate only. Local conditions may be more or less severe than indicated by region classification. A severe classification is where weather conditions result in significant snowfall combined with extended periods during which there is little or no natural thawing causing deicing salts to be used extensively.



MODEL#	(Width x Height)	Description of Product
Traditional Fireplace Series		
<i>For Indoor or Outdoor use*</i>		
TFS63	63"x 32"	BURNTECH™ FIREPLACE KIT - Use 16" Class A UL103 Chimney - Inc (2) BFPM525
TFS49	49"x 32"	BURNTECH™ FIREPLACE KIT - Use 14" Class A UL103 Chimney - Inc (1) BFPM525
TFS44-12	44"x 32"	BURNTECH™ FIREPLACE KIT - Use 12" Class A UL103 Chimney - Inc (1) BFPM525
TFS44-14	44"x 32"	BURNTECH™ FIREPLACE KIT - Use 14" Class A UL103 Chimney - Inc (1) BFPM525
TFS39-12	39"x 32"	BURNTECH™ FIREPLACE KIT - Use 12" Class A UL103 Chimney - Inc (1) BFPM525
TFS39-14	39"x 32"	BURNTECH™ FIREPLACE KIT - Use 14" Class A UL103 Chimney - Inc (1) BFPM525
TFS33-12	33"x 24"	BURNTECH™ FIREPLACE KIT - Use 12" Class A UL103 Chimney - Inc (1) BFPM525
TFS43-ST	43"x 32"	BURNTECH™ SEE-THRU FIREPLACE KIT - Use 16" Class A UL103 Chimney - Inc (1) BFPM525
<i>*All BURNTECH™ Traditional Fireplace Kits Installed Indoors Require Class A UL103 Flue Pipe (SOLD SEPERATELY)</i>		
Linear Fireplace Series		
<i>For Indoor or Outdoor use*</i>		
LFS72-H20	72"x 20"	BURNTECH™ FIREPLACE KIT - Use (2) 12" Class A UL103 Chimney - Inc (2) BFPM525
LFS72-H16	72"x 16"	BURNTECH™ FIREPLACE KIT - Use (2) 12" Class A UL103 Chimney - Inc (2) BFPM525
LFS63-H20	63"x 20"	BURNTECH™ FIREPLACE KIT - Use 16" Class A UL103 Chimney - Inc (2) BFPM525
LFS63-H16	63"x 16"	BURNTECH™ FIREPLACE KIT - Use 16" Class A UL103 Chimney - Inc (2) BFPM525
LFS63-STH20	63"x 20"	BURNTECH™ SEE-THRU FIREPLACE KIT - Use 16" Class A UL103 Chimney - Inc (2) BFPM525
LFS63-STH16	63"x 16"	BURNTECH™ SEE-THRU FIREPLACE KIT - Use 16" Class A UL103 Chimney - Inc (2) BFPM525
<i>*All BURNTECH™ Linear Fireplace Kits Installed Indoors Require Class A UL103 Flue Pipe (SOLD SEPERATELY)</i>		
Outdoor Fireplace Series		
<i>For Outdoor use only</i>		
OFS63	63"x 32"	BURNTECH™ FIREPLACE KIT - Includes (2) BFPM525 and 2' MCH 14" Flue
OFS49	49"x 32"	BURNTECH™ FIREPLACE KIT - Includes (1) BFPM525 and 2' MCH 14" Flue
OFS44	44"x 32"	BURNTECH™ FIREPLACE KIT - Includes (1) BFPM525 and 2' MCH 14" Flue
OFS39	39"x 32"	BURNTECH™ FIREPLACE KIT - Includes (1) BFPM525 and 2' MCH 14" Flue
OFS33	33"x 24"	BURNTECH™ FIREPLACE KIT - Includes (1) BFPM525 and 2' MCH 14" Flue
OFS43-ST	43"x 32"	BURNTECH™ SEE-THRU FIREPLACE KIT - Includes (1) BFPM525 and 2' MCH 14" Flue
OFS33-SF	33"x 16"	BURNTECH™ SMARTFIRE FIREPLACE KIT - Includes (1) BFPM525 and 2' MCH 14" SlimFlue
Vent-Free Series		
<i>For Outdoor use only*</i>		
VFS63	63"x 32"	BURNTECH™ VENT-FREE FIREPLACE KIT - Includes (1) (1) BFPM525
VFS49	49"x 32"	BURNTECH™ VENT-FREE FIREPLACE KIT - Includes (1) BFPM525
VFS44	44"x 32"	BURNTECH™ VENT-FREE FIREPLACE KIT - Includes (1) BFPM525
VFS39	39"x 32"	BURNTECH™ VENT-FREE FIREPLACE KIT - Includes (1) BFPM525
VFS33	33"x 32"	BURNTECH™ VENT-FREE FIREPLACE KIT - Includes (1) BFPM525
VFS43-ST	43"x 32"	BURNTECH™ SEE-THRU VENT-FREE FIREPLACE KIT Includes (1) BFPM525
<i>*All BURNTECH™ Vent-Free Kits Require An Approved Vent Free Gas Log Set (SOLD SEPERATELY)</i>		
Gas B-Vent Series		
<i>For Indoor Use Only</i>		
GBVS49	10"	BURNTECH™ B-VENT GAS APPLIANCE - Includes (1) BFPM525 (1) GBV-DH10
GBVS44	10"	BURNTECH™ B-VENT GAS APPLIANCE - Includes (1) BFPM525 (1) GBV-DH10
GBVS39	10"	BURNTECH™ B-VENT GAS APPLIANCE - Includes (1) BFPM525 (1) GBV-DH10
GBVS43-ST	12"	BURNTECH™ SEE-THRU B-VENT GAS APPLIANCE - Includes (1) BFPM525 (1) GBV-DH12
<i>*All BURNTECH™ B-Vent Fireplace Kits Require An Approved "Vented" Gas Log Set (SOLD SEPERATELY)</i>		
Outdoor Pizza Oven		
OPO-24		BURNTECH™ OUTDOOR WOOD BURNING PIZZA OVEN Inc (1) BFPM525 BURNTECH MORTAR
OPO-CHM		BURNTECH™ WOOD STORAGE CABINET AND PIZZA OVEN SUPPORT PLATFORM Raises Pizza Oven 22"H
Accessories		
BFPM525	50 LBS.	BUCKET BURNTECH™ FIREPLACE MORTAR
BFP4-AK	4"	COMBUSTION AIR KIT FOR BURNTECH™ FIREPLACE- Inc 3' Flexible Vent and Galvanized ExteriorHood
BFP115-SS		TENSION STRAPS FOR 33,39,43,44,49 BURNTECH™ FIREPLACE KITS (Nuts, Bolts, Washers Included)
BFP116-SS		TENSION STRAPS FOR 63" BURNTECH™ FIREPLACE KIT- (Nuts, Bolts, Washers Included)
BFP-ARC		MASONRY ARCH - FOR 33,39,43,44,49 BURNTECH™ FIREPLACE KITS
BFP-DCBKT		DAMPER CHAIN BRACKET For use with ANCHOR PLATE/DAMPER COMBO or TOP DAMPERS
BAP-IG	24" x 18" x 1"	ANCHOR PLATE HEAT RATED INSULATION GASKET- For use with all ANCHOR PLATES
SBK-AB8		PACKAGE OF (8) BRACKETS FOR METAL BASE KITS
Anchor Plates		
AP-AC12	*12"	AIR COOLED ANCHOR PLATE NO DAMPER <i>(For use with Air Cooled Chimney only)</i>
AP-AC14	*14"	AIR COOLED ANCHOR PLATE NO DAMPER <i>(For use with Air Cooled Chimney only)</i>
APD-AC12	*12"	AIR COOLED ANCHOR PLATE WITH BUILT IN DAMPER <i>(For use with Air Cooled Chimney only)</i>
APD-AC14	*14"	AIR COOLED ANCHOR PLATE WITH BUILT IN DAMPER <i>(For use with Air Cooled Chimney only)</i>
BV-10DH	*10"	ANCHOR PLATE/DRAFT HOOD - USE WITH B-VENT FIREPLACES ONLY
BV-12DH	*12"	ANCHOR PLATE/DRAFT HOOD - USE WITH B-VENT FIREPLACES ONLY
<i>*ALL ANCHOR PLATES REQUIRE HEAT RATED INSULATION GASKET AND HIGH TEMP CAULK (SOLD SEPERATELY)</i>		



MODEL#	(Width x Height)	Description of Product
Dampers		
FPD-48	48"	CAST IRON DAMPER - For TFS63 with Damper Blocks and Masonry Chimney (SOLD SEPERATELY)
FPD-42	42"	CAST IRON DAMPER - For TFS49 with Damper Blocks and Masonry Chimney (SOLD SEPERATELY)
FPD-36	36"	CAST IRON DAMPER - For TFS44, TFS43-ST with Damper Blocks and Masonry Chimney (SOLD SEP.)
FPD-30	30"	CAST IRON DAMPER - For TFS39 with Damper Blocks and Masonry Chimney (SOLD SEPERATELY)
FPD-24	24"	CAST IRON DAMPER - For TFS33 with Damper Blocks and Masonry Chimney (SOLD SEPERATELY)
Masonry Damper Blocks		
DB-48		DAMPER BLOCK - For use with the TFS63 And 48" CAST IRON DAMPERS - (SOLD SEPERATELY)
DB-42		DAMPER BLOCK - For use with the TFS49 And 42" CAST IRON DAMPERS - (SOLD SEPERATELY)
DB-36		DAMPER BLOCK - For use with the TFS44 And 36" CAST IRON DAMPERS - (SOLD SEPERATELY)
DB-30		DAMPER BLOCK - For use with the TFS39 And 30" CAST IRON DAMPERS - (SOLD SEPERATELY)
DB-24		DAMPER BLOCK - For use with the TFS33 And 24" CAST IRON DAMPERS - (SOLD SEPERATELY)
Metal Base Kits <i>For Raise Hearth Applications</i>		
BK63	8"	STRUCTURAL METAL BASE KIT FOR 63" BURNTTECH™ FIREPLACE KITS
BK49	6"	STRUCTURAL METAL BASE KIT FOR 49" BURNTTECH™ FIREPLACE KITS
BK44	6"	STRUCTURAL METAL BASE KIT FOR 44" BURNTTECH™ FIREPLACE KITS
BK43	8"	STRUCTURAL METAL BASE KIT FOR 43" BURNTTECH™ FIREPLACE KITS
BK39	6"	STRUCTURAL METAL BASE KIT FOR 39" BURNTTECH™ FIREPLACE KITS
BK33	6"	STRUCTURAL METAL BASE KIT FOR 33" BURNTTECH™ FIREPLACE KITS
<i>STRUCTURAL METAL BASE KITS Include Insulation Blanket, Hearth Ember Protector, Brackets and Hardware</i>		
Firebox Kits <i>Brick Firebox Kit Consist of 2 Sidewalls 1 Backwall and 1 Interior Hearth Floor</i>		
FBK63SHB	63"	BURNTTECH™ FIREPLACE SPLIT HERRINGBONE FIREBOX KIT
FBK63FRB	63"	BURNTTECH™ FIREPLACE FULL SIZE RUNNING BOND FIREBOX KIT
FBK49SHB	49"	BURNTTECH™ FIREPLACE SPLIT HERRINGBONE FIREBOX KIT
FBK49FRB	49"	BURNTTECH™ FIREPLACE FULL SIZE RUNNING BOND FIREBOX KIT
FBK44SHB	44"	BURNTTECH™ FIREPLACE SPLIT HERRINGBONE FIREBOX KIT
FBK44FRB	44"	BURNTTECH™ FIREPLACE FULL SIZE RUNNING BOND FIREBOX KIT
FBK39SHB	39"	BURNTTECH™ FIREPLACE SPLIT HERRINGBONE FIREBOX KIT
FBK39FRB	39"	BURNTTECH™ FIREPLACE FULL SIZE RUNNING BOND FIREBOX KIT
FBK33SHB	33"	BURNTTECH™ FIREPLACE SPLIT HERRINGBONE FIREBOX KIT
FBK33FRB	33"	BURNTTECH™ FIREPLACE FULL SIZE RUNNING BOND FIREBOX KIT
FBK43SHB-ST	43"	BURNTTECH™ SEE-THRU FIREPLACE SPLIT HERRINGBONE FIREBOX KIT
FBK43FRB-ST	43"	BURNTTECH™ SEE-THRU FIREPLACE FULL SIZE RUNNING BOND FIREBOX KIT
Masonry Chimney System <i>Fireplace must have 14" Flue Opening</i>		
MCH814-8TS	8'	MASONRY CHIMNEY SYSTEM- (12) Sections: 14" I.D. x 8"H - Inc (1) MCH414-ILS
MCH414-4TS	4'	PATIO SYSTEM - 6 Sections: 14" I.D. x 8"H - Inc (1) MCH414-ILS
MCH-1CRSE		(1) 8"H CHIMNEY LINER COMPLETE. Includes (1) Chimney OuterLiner (1) Slimflue Chimney Inner Liner
MCH814-IL		SLIMFLUE MASONRY CHIMNEY INNER LINER (INDIVIDUAL) - 14" I.D. x 8"H
MCH814-OL		MASONRY CHIMNEY OUTER LINER (INDIVIDUAL) - 14" I.D. x 8"H
MCH414-ILS		SLIMFLUE MASONRY CHIMNEY INNER LINER (STARTER COURSE) - 14" I.D. x 4"H
MCH814-BL		MASONRY CHIMNEY BRICK LEDGE - 14" I.D. x 4"H
MCH814-OS		MASONRY CHIMNEY OFFSET ELBOW (30 DEGREES) - 14" I.D. x 4"H
Height Extension Kits <i>Includes (1) Rear Wall and (2) Side Walls</i>		
HEK63	8"	Tall HEIGHT EXTENSION KIT FOR 63" BURNTTECH™ FIREPLACE
HEK49	8"	Tall HEIGHT EXTENSION KIT FOR 49" BURNTTECH™ FIREPLACE
HEK44	8"	Tall HEIGHT EXTENSION KIT FOR 44" BURNTTECH™ FIREPLACE
HEK39	8"	Tall HEIGHT EXTENSION KIT FOR 39" BURNTTECH™ FIREPLACE
HEK33	8"	Tall HEIGHT EXTENSION KIT FOR 33" BURNTTECH™ FIREPLACE
HEK43-ST	8"	Tall HEIGHT EXTENSION KIT FOR 43" SEE-THRU BURNTTECH™ FIREPLACE
Outdoor Fire Pits		
BOFP16-48	48"	ROUND FIRE RING 2 COURSES TALL WITH CAP (18" TALL)
BOFP24-48	48"	ROUND FIRE RING 3 COURSES TALL WITH CAP (26" TALL)
BOFP-48		BURNER FOR 48" FIRE RING - NATURAL GAS WITH BLACK VOLCANIC ROCK
BOFP-48		BURNER FOR 48" FIRE RING - PROPANE GAS WITH BLACK VOLCANIC ROCK
<i>Fire Rings do <u>not</u> come with a bucket of dry mortar—must be purchased separately</i>		

**A 20% Restock fee will apply on all returned items. Returned Items must be in new condition with original packaging. All flue pipe and accessories can only be returned if packing is unopened from the original manufacturer packaging.

Lifetime Limited Warranty

Burntech® Fireplace Solutions

Burntech® Fireplace Solutions, Inc. warrants all Burntech® Fireplaces to be free from defects in materials that adversely affect fireplace performance for the lifetime of the product from the date of purchase, subject to the terms and conditions of this limited warranty. Burntech® Fireplace Solutions does not warrant accessory chimney, outside air ducts and devices not manufactured by Burntech® Fireplace Solutions.

This warranty covers only products manufactured by Burntech® Fireplace Solutions, specifically the modular masonry fireplace, and **NO WARRANTY, EXPRESS OR IMPLIED, EXTENDS TO ANY OF THE HARDWARE, FOUNDATION, VENTING, DUCTS, OR ACCESSORIES. THIS WARRANTY DOES NOT COVER DRAFTING, SMOKING, OR SOOTING OF THE FIREPLACE SYSTEM.** Factors beyond the manufacturer's control affect drafting, smoking, and sooting and Burntech® Fireplace Solutions cannot guarantee these aspects of performance.

Coverage under this warranty is subject to the following conditions and exclusions:

- This warranty is null and void when the fireplaces are not installed pursuant to the installation instructions provided by Burntech® Fireplace Solutions or local building codes have not been followed completely.
- Glass is warranted against thermal breakage only and only on models that are manufactured by Burntech® Fireplace Solutions with a glass front. On Direct Vent models the safety glass or safety screen must be kept in front of this glass when fireplace is in use. Safety screen must be used on all models when in use.
- This warranty does not apply to any component or part that shows evidence of misuse, abuse, improper installation, accident or lack of regular maintenance. Burntech® Fireplace Solutions is not responsible for misuse or mishandling of component parts.
- This warranty does not apply to any damage sustained to the appliance while in transit.
- Neither Burntech® Fireplace Solutions, nor any affiliate thereof, is responsible for any labor costs or indirect costs incurred for the replacement of defective components. Any covered component that, in our judgment, is defective shall be repaired, replaced or refunded at Burntech® Fireplace Solutions's option.
- Nothing in this warranty makes Burntech® Fireplace Solutions, or any affiliate thereof, liable in any respect for any injury or damage to the building or structure in which the fireplace has been installed or to the persons or property therein arising out of the use, misuse, or installation of properly manufactured Burntech® Fireplace Solutions products.
- The fireplace must be used in accordance with operating instructions. The grate or andirons must be installed when using the fireplace.

NEITHER Burntech® Fireplace Solutions, NOR ANY AFFILIATE THEREOF, SHALL BE HELD LIABLE FOR ANY INCIDENTAL OR CONSEQUENTIAL DAMAGES OR EXPENSES ARISING OUT OF THE USE OF THE FIREPLACE. ALL SUCH DAMAGES AND EXPENSES ARE HEREBY EXCLUDED. Some states do not allow the exclusion or limitation of incidental or consequential damages, so the above limitation or exclusion may not apply to you.

If a component is found to be defective under the terms of this warranty the party this warranty is extended shall, notify Burntech® Fireplace Solutions, 6520 Platt Ave #577, West Hills, CA 91307 in writing, by registered mail, within thirty (30) days following the discovery of the defect within the lifetime warranty period. The letter shall include proof of purchase and state the (1) date of purchase, model number and serial number ; (2) place of purchase; (3) address of installation; (4) name, address and phone number of the homeowner; and (5) a brief description of the defect.

This warranty applies only to those fireplaces installed in the continental United States, Alaska and Canada. If any part of this warranty is found to be unenforceable, the remaining parts shall remain in force and effect.

THE FOREGOING WARRANTY IS EXCLUSIVE AND IS IN LIEU OF ALL OTHER WARRANTIES, TERMS OR CONDITIONS, EXPRESS OR IMPLIED EITHER IN FACT OR BY OPERATION OF LAW. Burntech® Fireplace Solutions HEREBY DISCLAIMS ALL GUARANTEES AND WARRANTIES, EXPRESS OR IMPLIED, BEYOND THE WARRANTIES SET FORTH HEREIN, INCLUDING BUT NOT LIMITED TO WARRANTIES OF MERCHANTABILITY OR FITNESS FOR A PARTICULAR PURPOSE. Some states do not allow limitations on how long an implied warranty lasts, so the above limitation may not apply to you.

Burntech® Fireplace Solutions

6520 Platt Ave #577, West Hills, CA 91307

Main: (818)564-4253, Fax: (818) 564-4232

WWW.BURNTECH.COM

Revised 12/05/2012

