



MODEL GTL/UTL CHIMNEY INSTALLATION INSTRUCTIONS

A MAJOR CAUSE OF CHIMNEY RELATED FIRES IS FAILURE TO MAINTAIN REQUIRED CLEARANCES (AIR SPACES) TO COMBUSTIBLE MATERIALS. IT IS OF UTMOST IMPORTANCE THAT THIS CHIMNEY BE INSTALLED ONLY IN ACCORDANCE WITH THESE INSTRUCTIONS.

MODEL GTL/UTL CHIMNEY SYSTEM PART NAMES AND NUMBERS

Model GTL (Galva Temp Large) and UTL (Ultra Temp Large) are part of the MetalBest Chimney System (MCS). The complete part number is prefixed with the ID size, followed by three letters identifying the system followed by the actual part identifier.

All Model GTL and UTL chimney components contain the letters GTL or UTL in their prefix. Figs. 1 and 2 show the names and locations of commonly used chimney parts. These figures use only the last portion of the part number. The complete part number is prefixed with I.D. size, followed by chimney model and part number. (See Figs. 1 and 2)

FOR EXAMPLE :

Model GTL
|
16" Inside Diameter — **16GTL-36** — 36" Pipe Length

16GTL-AIS — Attic Insulation Shield

or

Model UTL
|
16" Inside Diameter — **16UTL-36** — 36" Pipe Length

16UTL-AIS — Attic Insulation Shield

CLEARANCES / AIR SPACE ONLY

The minimum clearance to Model GTL/UTL pipe means AIR SPACE ONLY. The 2 inch clearance to the pipe, and the spaces around supports **must not** be filled with any type of insulation. In attics with blown-in or batt insulation, the chimney must either be fully enclosed or an Attic Insulation Shield must be used to create and maintain the proper minimum airspace.

SPECIAL WARNING ON CELLULOSE INSULATION

Cellulose insulation in direct contact with a hot chimney can ignite and smolder, and can set fire to ordinary wood framing materials. The AIR SPACE ONLY requirement applies to all blown-in or loose fill insulations, but is especially applicable to cellulose insulation, which may be made from old newspapers or other cellulose materials. The Attic Insulation Shield or a full enclosure with appropriate fire stops must be used to keep all insulation the proper distance away from the chimney.



WARNING

Failure to follow the installation instructions could cause **FIRE, CARBON MONOXIDE POISONING, OR DEATH.** If you are unsure of installation requirements, call the Phone Number listed on the instructions, 1.800.433.6341 or visit www.selkirkcorp.com.

PERMITS

Contact your local Building Official or Fire Official regarding permits, restrictions, and installation inspections in your area.

DIAMETERS AND APPLICATIONS

Model GTL/UTL 1700°F is a complete chimney system tested and listed to UL Test Standard 103. Model GTL/UTL is made in 16", 18", 20", 22" and 24" diameters. All sizes comply fully with the requirements of the Standard for Factory-Built Chimneys, Residential Type and Building Heating Appliance ANSI/UL 103. Chimneys installed in accordance with these instructions will comply with national safety standards such as NFPA 31, 54 and 211.

Model GTL/UTL may be used for gas, wood and liquid fuel-fired appliances when sized in accordance with the appliance manufacturer's instructions.

NOTE:

Use only Model GTL/UTL Listed components and accessories. Do not attempt to fabricate your own support or accessories.

These Model GTL/UTL general instructions are furnished with all UL listed Chimney Anchor Plates. They cover important safety precautions in the installation, operation and maintenance of your chimney. Anyone installing Model GTL/UTL chimney should review these instructions as well as those furnished with the other parts of the chimney system. Selkirk chimney parts LISTED and produced under the Factory Inspection and Follow-Up program of Underwriters Laboratories, Inc. carry the LISTING MARK illustrated here.



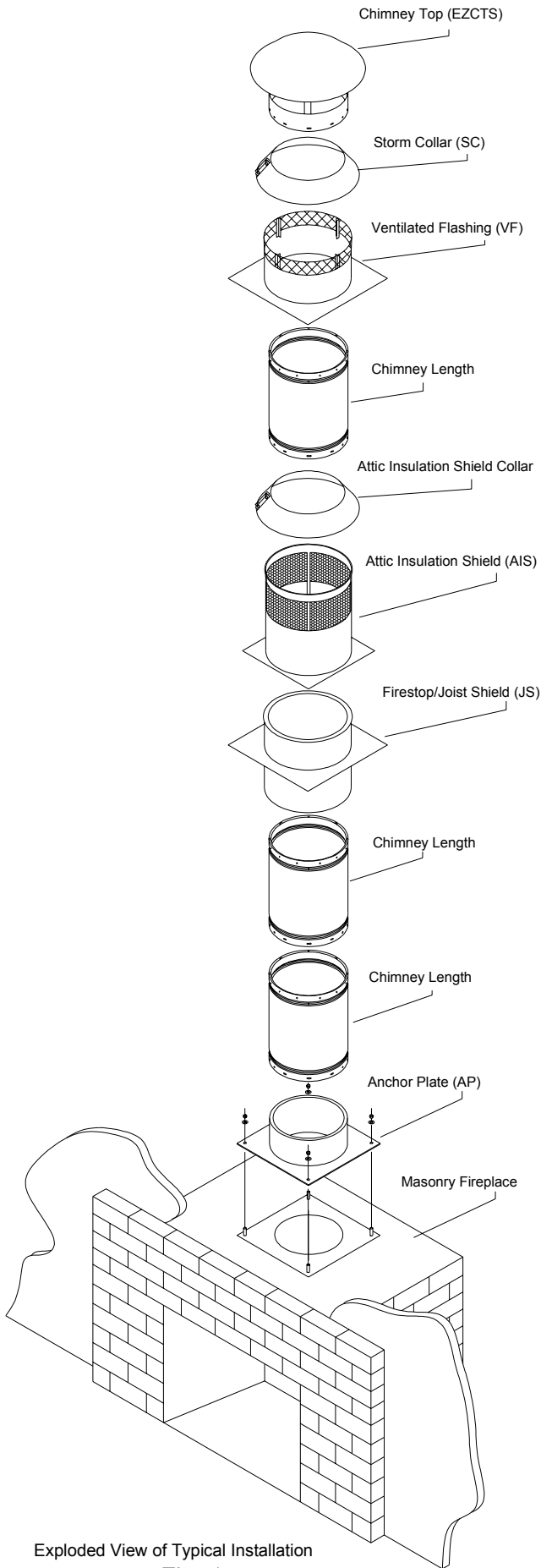

Exploded View of Typical Installation
Fig. 1

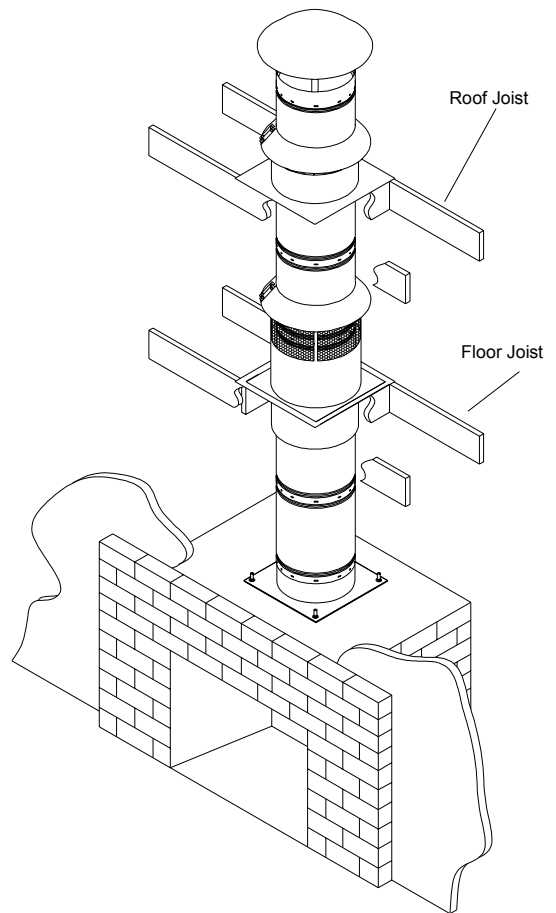

Assembled View of Typical Installation
Fig. 2

Model GTL/UTL is designed for gravity venting only and is suitable for applications involving masonry fireplaces and existing masonry chimneys.

Non-residential appliances which may cause positive pressure in the chimney should use a Selkirk Model PS or IPS system.

CHIMNEY HEIGHT AND SIZE

Follow the appliance manufacturer's instructions to determine chimney diameter and clearances between combustible materials and your heating appliance. Never choose a chimney with an inside diameter smaller than your appliance's outlet. If you are connecting to a masonry fireplace, these instructions contain a "Selector Chart" so you can correctly size your system based on its height and the fireplace opening. (See Fig. 3)

Before beginning installation of the chimney, be sure that the selected size is adequate for the fireplace and the selected height of the Chimney Round Top termination is high enough to conform to building code requirements. Chimneys are required to extend at least 3 feet above the highest point where they pass through the roof of a building, and at least two feet higher than any portion of a building within 10 feet. (National Fire Protection Association Standards Nos. 31, 54, and 211). See following chart.

Chimney Size: (Inside Dimension)	16"	18"	20"	22"	24"
Minimum Framed Opening Size (Square)	22" x 22"	24" x 24"	26" x 26"	28" x 28"	30" x 30"

**WHEN INSTALLING YOUR CHIMNEY,
REMEMBER...SAFETY FIRST**

You may well have a basic knowledge of carpentry and the use of hand tools. However it is important that you also review the rules of safety on the following pages. If you have any doubt about your ability to complete your installation in a skilled manner, you should arrange for a professional installation.

RULES FOR SAFETY DURING INSTALLATION

1. Read all installation sheets. Look for them in the cartons, or ask your dealer for a complete set or download from www.selkirkinc.com. Keep the instructions handy and save them for future reference. If the chimney is being installed by someone other than the homeowner, they should provide the homeowner with the installation instructions upon completion.
2. Check your local building or fire code for all requirements affecting the fuel-burning appliance and its chimney.
3. Obtain a building permit for both the appliance and the chimney. Contact local building or fire officials about restrictions and installation inspection in your area.
4. Be very careful around electrical wiring and be sure it is secured at least 2 inches away from any part of the chimney. If wiring must be relocated, hire a professional electrician.
5. Be sure that ladders are in good condition and always rest on a level firm surface.

6. Wear cut resistant gloves when handling sheet metal parts with sharp edges.
7. Be sure that electrically powered tools are properly grounded.

EQUIPMENT & MATERIALS

Equipment you may need:

- Drill/Driver
- Caulking Gun
- Screwdrivers (Phillips & Standard)
- Saber or Keyhole Saw
- Dependable Ladder
- Proper Gloves & Shoes
- Hammer
- Plumb Bob
- Tin Snips
- Level
- Tape Measure
- Eye Protection

Materials You May Need:

- Mortar
- 1/4" x 2" long Masonry Anchors, with washers and nuts
- Non-hardening Waterproof Sealant
- 600°F RTV Silicone Sealant
- 8 Penny Nails
- Roofing Nails
- #8 x 1/2" Stainless Steel Sheet Metal Screws

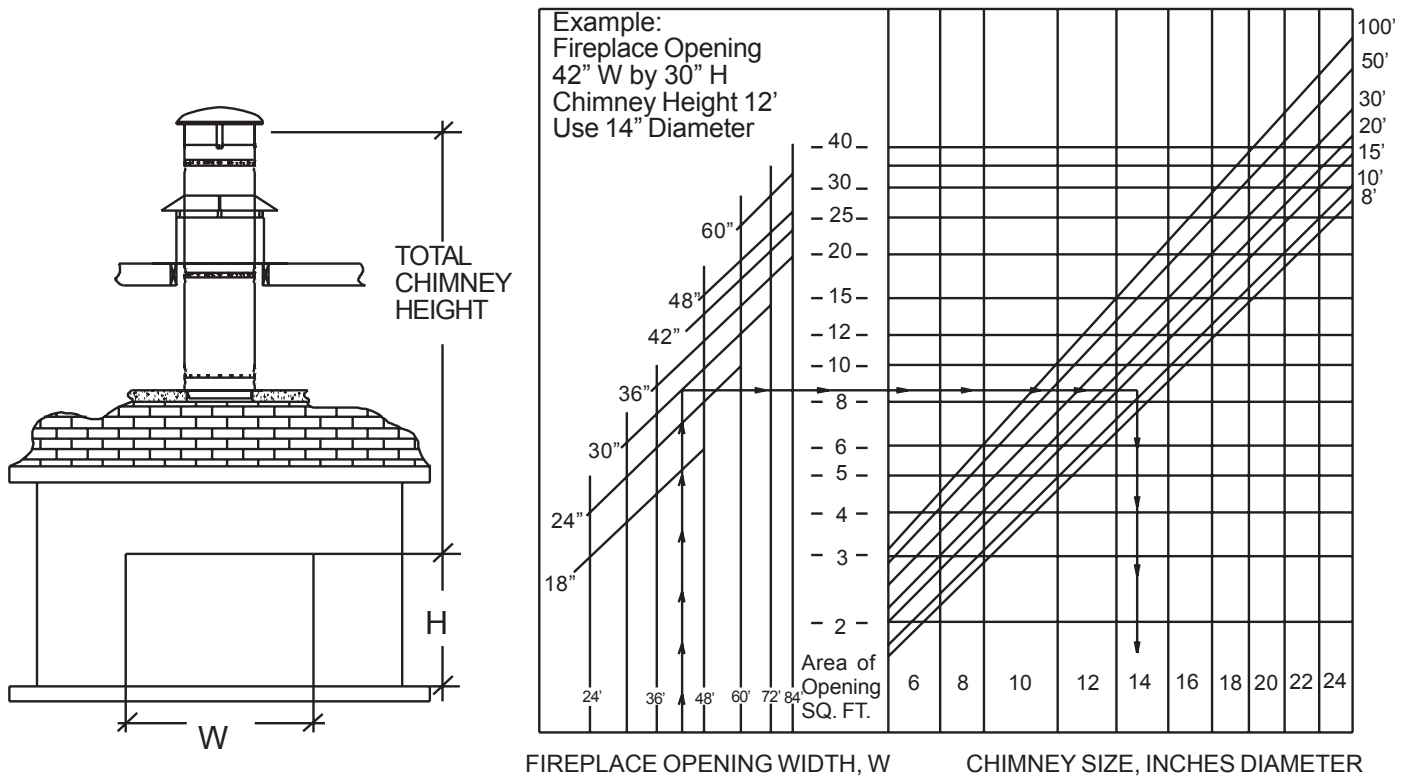

Fig. 3 - CHIMNEY SIZING CHART FOR FIREPLACES

ANCHOR PLATE (AP)

The Anchor Plate (AP) provides a connection from a masonry fireplace to Model GTL/UTL. The Anchor Plate may also be used to attach Model GTL/UTL to an existing masonry chimney. The method for making the transition from an existing masonry chimney to the GTL/UTL is known as the "Bond Beam" transition method and is detailed in Fig. 5a.

For attachment to a masonry fireplace:

1. Using the Anchor Plate as a template centered over the outlet opening, drill and anchor four 1/4" diameter bolts 2" long securely into the top of the masonry fireplace.
2. Apply a bed of mortar approximately 3/4" in depth and 3" in width completely around the fireplace opening. Make sure the threaded ends of the bolts protrude a minimum of 1" above the bed of mortar.
3. While the mortar is still damp, place and level the Anchor Plate over the extended studs. Secure, using a washer and nut for each bolt. (See Fig. 4)
4. Check the plate for level and allow mortar to set.
5. Place a section of chimney onto the Anchor Plate and secure to Anchor Plate with 4 #8 x 1/2" sheet metal screws. Up to 35' of chimney may be stacked on the Anchor Plate. Use an Interior Resupport (IR) for every additional 16' of height needed.

For attachment to an existing masonry chimney using the "Bond Beam" transition method:

The masonry chimney should be leveled at the appropriate height and a concrete Bond Beam should be properly constructed by a qualified person / contractor as shown in Fig.5a. Unless otherwise specified by local code, the Bond Beam should be a minimum of 6" thick and provide an

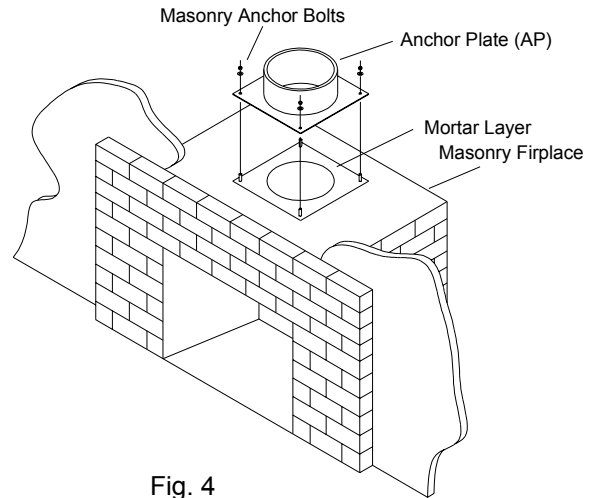

Fig. 4

uninterrupted, smooth transition from the existing masonry flue to the inlet of the Anchor Plate.

The Model GTL/UTL should be sized such that its inner cross-sectional area is approximately equivalent to that of the existing masonry flue. Reference Selkirk MetalBest Sizing Handbook.

Although not mandatory, it is recommended to apply a 3/4" deep bed of mortar on top of the Bond Beam and ultimately attach the Anchor Plate to the bed of mortar with the use of four 1/4" diameter, 2" long anchor bolts. (See Fig. 5a and 5b). Regardless, the top surface (whether Bond Beam or mortar) should be level.

If an enclosure is to be constructed around the MCS chimney, be sure to incorporate the proper 2" airspace clearance requirement.

Local codes may permit or require minor variations in the Bond Beam construction. Contact Local Code Authorities for specific requirements in your area. (See Fig.5a and 5b)

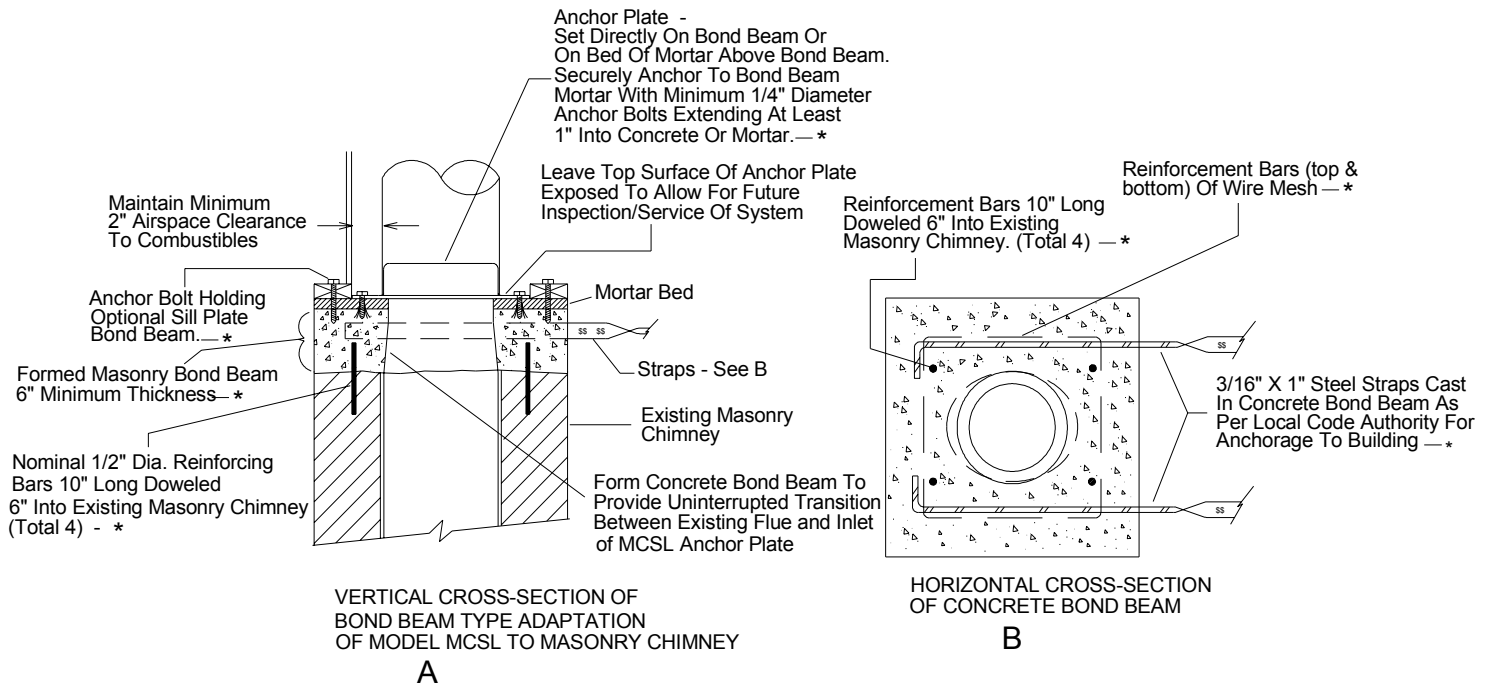

A

B

- All Dimensions, Sizes and Material Specifications
 * — Relating to Bond Beam Construction are Subject to Modification Per Local Code Requirements

Fig. 5a

STRAIGHT LENGTHS / JOINT SECURITY

Model GTL/UTL comes in lengths of 12", 18", 24" and 36". Starting at the Anchor Plate (AP) set inlet end (Female) of pipe section down over the outlet end (Male) of previous piece until fully seated. Secure with four, #8 x 1/2" stainless steel sheet metal screws (see **Note** below) by inserting them through the aligned holes. The sheet metal screws must be evenly spaced around the circumference of the joint.

(See Fig. 6)

Note: It is permissible to use zinc plated screws when securing/joining Model GTL (galvanized outer wall) chimney lengths or elbows. **Do not** use zinc plated screws with Model UTL (stainless outer wall).

30° INSULATED ELBOW / OFFSETS

MetalBest Large Diameter Chimney 30-degree Elbow adapts the chimney for installations where the termination cannot be located directly above the initial vertical run of chimney. The maximum allowable offset is 30 degrees from vertical. The maximum allowable inclined length is 96" unless resupported every 4 feet. Two separate offsets per system are permitted.

(See Fig. 7)
Resupport the chimney at the first section above the upper elbow by using an Interior Resupport. If the offset sections of a chimney are in an interior occupied area, they must be fully enclosed with a minimum of 2 inches air space clearance.

A minimum of 4, #8 x 1/2" stainless steel sheet metal screws (see **Note**) must be used to couple an elbow/offset to another elbow/offset or pipe section and must be evenly spaced around the circumference of the joint.

INTERIOR RESUPPORT ASSEMBLY (IR)

The Interior Resupport Assembly is comprised of two supports with attached straps. The Interior Resupport may be used for all sizes of Model GTL/UTL chimney. The Interior Resupport Assembly allows for two different methods of chimney resupport. The first method is used when an immediate section of chimney above the upper offset passes through a joist area. With the proper Firestop /Joist Shield in place, attach the Supports to the chimney pipe (preferably at a joint), using 2 sheet metal screws per support. (See Fig. 8) Make sure the Supports are 180 deg. (opposite) from each other. The Interior Resupport straps are then nailed to the framing joists with at least two 8-penny nails per strap. The maximum length of chimney which may be supported is 16 feet, which includes the offset lengths below, any vertical run to the resupport and the vertical run above the Interior Resupport. It does not include the length below the lower Elbow/ Offset, which is supported from below.

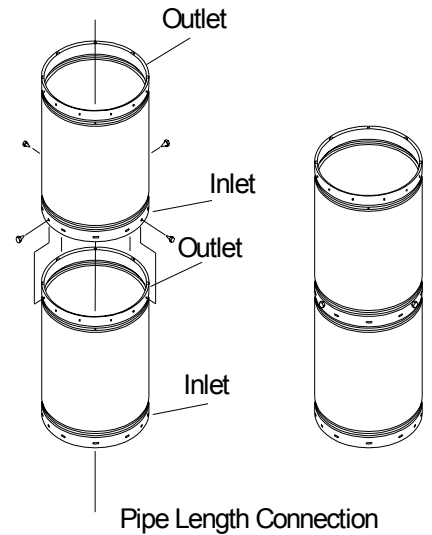

Fig 6

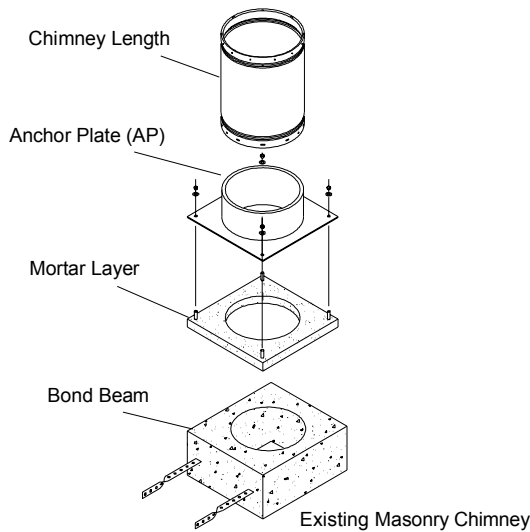
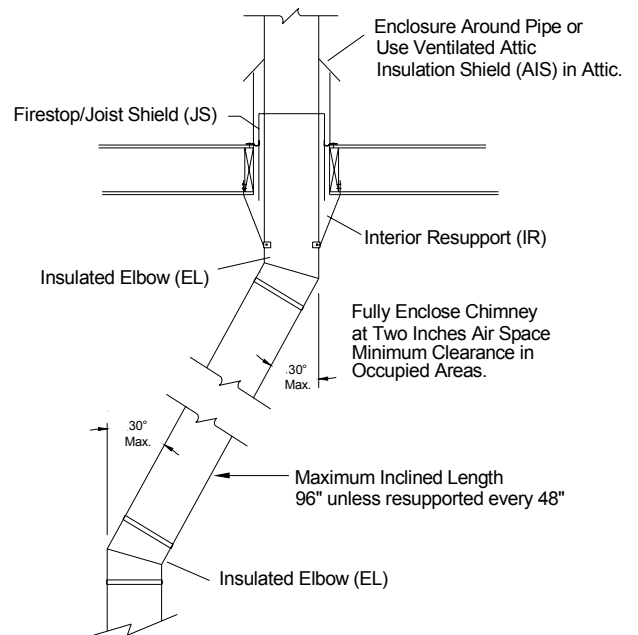

Fig. 5b



ELBOW/ OFFSET INSTALLATION
FIG. 7

Note: Fig. 7 represents a single offset. Two separate offsets per system are permitted.

In a non-occupied attic area the chimney may be fully enclosed or an Attic Insulation Shield may be used. Use additional Interior Resupport/s to accommodate additional length as necessary.

The second means of support is used primarily when the immediate sections of the upper elbow do not pass through a joist area and resupport is necessary. Install support immediately below the elbow (preferably at a joint) and nail the straps to the framing with at least two 8-penny nails per strap. Observe the two-inch air space minimum clearance between the chimney and framing. The same 16-foot limit of supportable chimney length applies to this resupport method.

FIRESTOPPING

A Firestop is any part of the building structure which prevents the spread of a fire or circulation of air. Where the chimney is enclosed and framed at 2" clearance, a Firestop/Joist Shield (JS) is the proper firestop to use at every floor.

If the enclosure or space around the Model GTL/UTL is larger than usual, or irregular in shape, attach galvanized metal plates 28 gauge or heavier all around the edges of the Firestop/Joist Shield as necessary. These plates should be wide enough so that when installed, the gap between the Firestop/Joist Shield and the enclosure is closed to vertical air circulation around the chimney and the pipe is securely spaced and centered.

For firestopping to be fully effective, all ceiling and floor penetrations should be fully framed and closed on all four vertical sides. This framing helps delay vertical spread of fire and controls unnecessary vertical air leakage through intermediate floors. (See Fig. 9)

ENCLOSURE:

Interior or exterior residential chimneys should be enclosed where they extend through closets, storage areas, or habitable spaces where persons or combustible materials could contact the surface of the chimney. The space between the enclosure and chimney should be at least the required minimum 2" INCHES AIR SPACE CLEARANCE. While properly installed firestops or supports help maintain the necessary clearances to combustibles at ceilings or joist areas, there are no special parts to maintain clearance to inside surfaces of walls or enclosures; therefore, the builder and the chimney installer should take all necessary precautions to assure that this 2 inch minimum clearance or more is maintained.

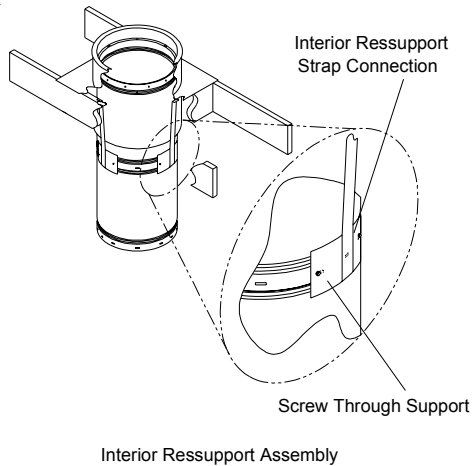

Fig 8

UNOCCUPIED ATTICS

In unoccupied attics, it is very important to be sure that blown-in or other insulation does not come in contact with the chimney. It is highly recommended that a full enclosure that extends to the roof be built in the attic. However, it need only be finished well enough to keep insulation and stored furnishings away from the chimney. As an option a ventilated Attic Insulation Shield (AIS) is available in the event a full enclosure cannot be built. (See Fig. 10). A chimney enclosure is also highly recommended for any chimney located outside of the building wall. This enclosure can be helpful in reducing internal condensation, creosote build-up and metal deterioration. Also the enclosure, by protecting the chimney from cold outdoor temperatures, may improve draft and appliance operation. At the upper end of this outdoor enclosure, the chimney should be flashed and weatherproofed.

Regardless of the benefits of the exterior enclosure, better chimney and appliance operation will be obtained if the chimney is located entirely inside the heated part of the building (except of course for the part above the roof).

Enclosures of ordinary wood framing with gypsum drywall or plywood walls may be built only in one and two-family dwellings. For other types of buildings, multiple occupancies or high rise construction, additional fire resistance is required for enclosures as follows:

A factory-built chimney that extends through any zone above that on which the connected appliance is located is to be provided with an enclosure having a fire resistance rating equal to or greater than that of the floor or roof assemblies through which it passes.

Even with a fire resistance rated enclosure, the use of Firestops at every floor level is recommended to stabilize the chimney and to retard possible fire spread external to the chimney.

Remember that the most important clearance requirement is that it must be AIR SPACE.

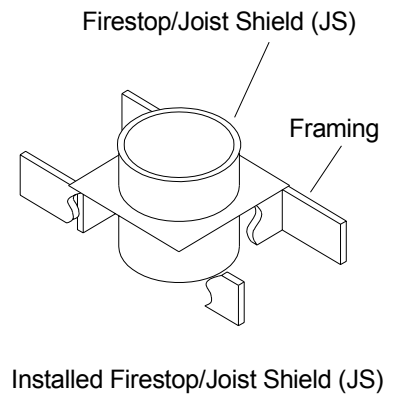

Fig. 9

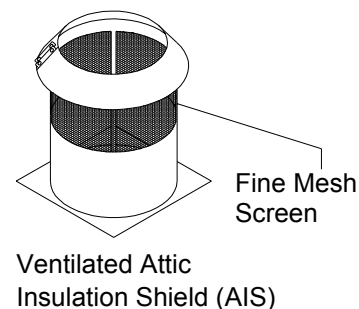

Fig. 10

STABILIZER PLATE

A Stabilizer Plate provides lateral support for a vertical chimney only. It is used to steady a vertical chimney when the chimney is installed within an oversized enclosure where the pipe does not pass through a ceiling/floor or joist area. The purpose of the Stabilizer Plate is to offer a convenient method of maintaining pipe location within the center of an enclosure. The stabilizer plate does NOT provide support for the weight of the chimney and should never be used as a replacement for an Anchor Plate or as a resupport. The Stabilizer Plate is NOT a firestop and is NOT intended to be used as a firestop. Only a Firestop/Joist shield should be employed where firestopping is recommended or required for safety (see the Firestopping section of this installation instruction sheet). The spacer ring attached to the bottom of the stabilizer is to assist with maintaining a minimum clearance to combustibles.

Follow these steps to install the stabilizer plate within an oversized enclosure.

- 1) Build a support structure inside the enclosure that consists of two (2) parallel, level braces with the planned chimney centered between. Space them at a distance equal to four inches (4") larger than the chimney O.D. (Fig. 11).
- 2) Align the center hole of the stabilizer plate with the outer wall of the pipe, with the spacer ring facing the framing. Slide the plate down the pipe and position the spacer ring between the framing supports. The spacer ring attached to the bottom of the plate is to assist in maintaining the minimum required air space clearance to combustibles.
- 3) Secure the plate to the framing using appropriate fasteners, such as nails with wood framing members.

As an alternate method of providing lateral stability, metal angle bracing or strapping may be used (Fig 12); or, a set of four (4) Interior Resupports, installed in a horizontal fashion (Fig 13), may be used within an oversize enclosure.

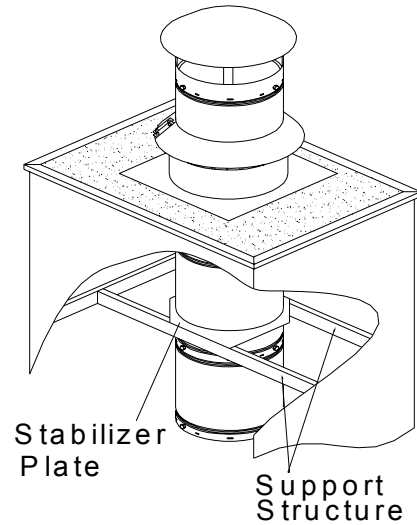
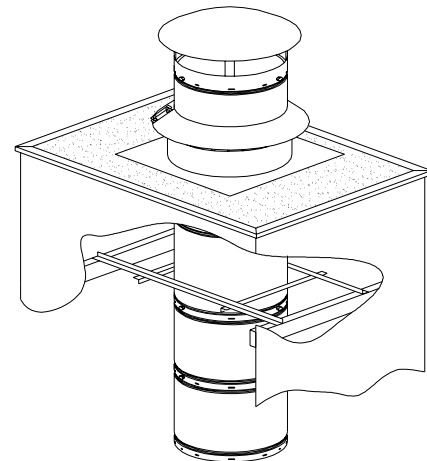
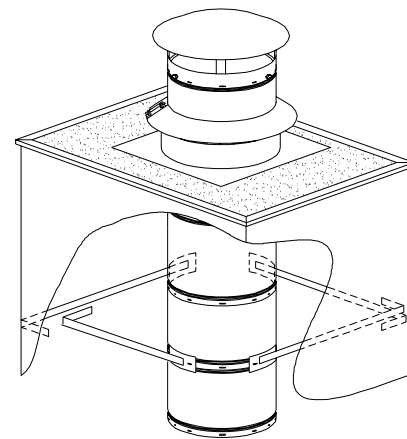

Fig 11



1" x 1" x 1/16" Thick Angle used as a stabilizer within an oversized enclosure

Fig 12



Interior Resupport Assembly used as a stabilizer within an oversized enclosure

Fig 13

VENTILATED FLASHING / STORMCOLLAR (VF / SC)

To Install a Flashing and Storm Collar:

1. Finish the chimney to its desired height. Maintain 2" clearance to combustibles where the chimney passes through the roof.
2. Place the Flashing over the chimney pipe and nail securely to the roof through all four sides of the flange. Use nails with neoprene washers, or cover the nail heads with a waterproof mastic.
3. Seal the space between the roof and the Flashing flange with a waterproof mastic sealer.
4. Place the Storm Collar over the chimney until it touches the Flashing's ventilation screen. Tighten the friction tabs of the Storm Collar until it fits snugly against the pipe. Seal area between the pipe and the Storm Collar with a mastic sealer or silicone sealant.

CHIMNEY TOP (EZCT)

To install Chimney Top:

1. Place Chimney Top over installed chimney pipe such that the outlet end of the pipe has engaged the collar of the Chimney Top.
2. Press down evenly on Top's dome until the Top has become firmly seated.
3. Attach Chimney Top using a minimum 4, #8 x 1/2" sheet metal screws.
4. To Remove the Top simply remove the 4, #8 x 1/2" sheet metal screws and, while grasping the Top's Dome, carefully and evenly lift straight up.

CUSTOM CHASE TOPS

As an alternative to using Model UTL/GTL, Part # UTL-TF, on chase top installations, it is permissible to substitute a non-Selkirk, metal chase cover if the guidelines shown below are followed.

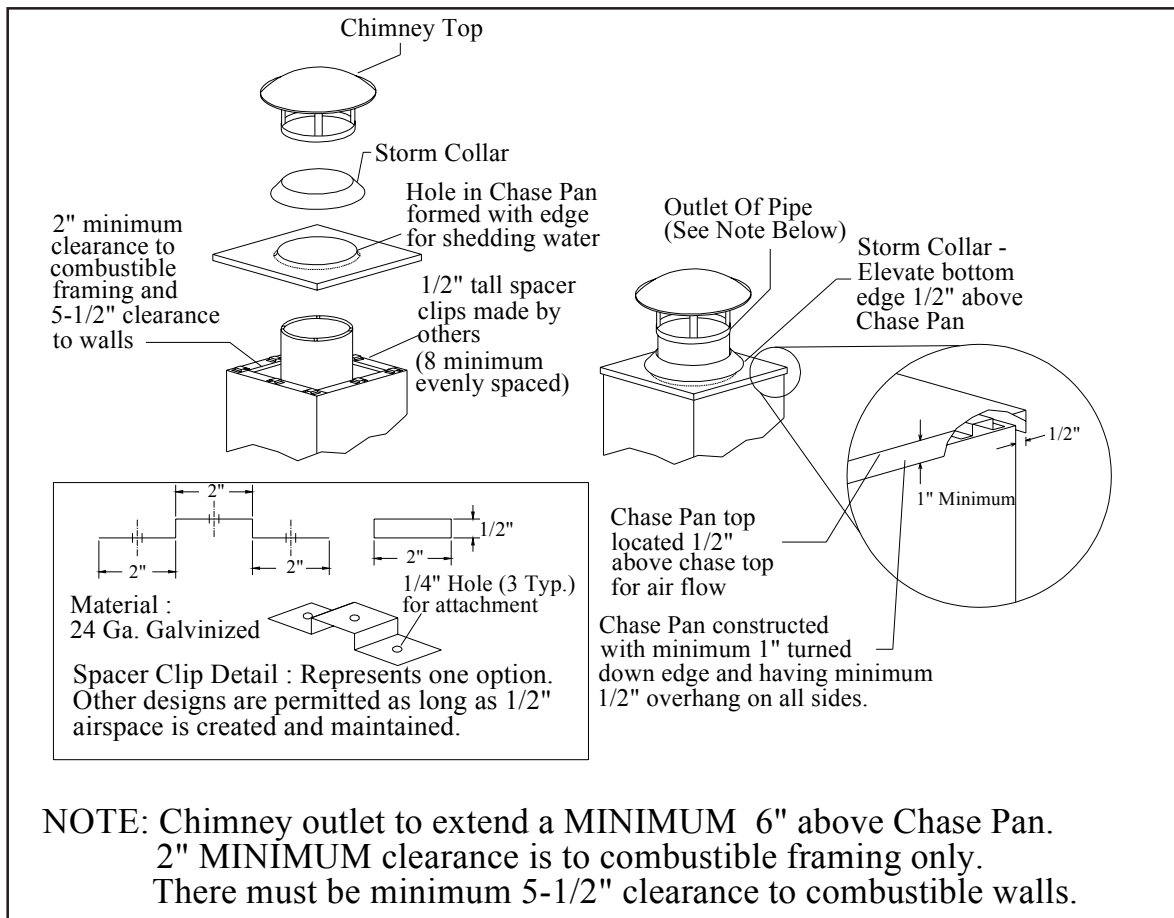

SHROUDS

In some areas, chimneys are permitted to be installed with a decorative shroud surrounding the standard termination cap. There are three styles of shrouds that are now permissible to use with MCS Chimney systems. They are referred to as Pyramid, Mailbox, and House styles. Each individual style has its own set of criteria. Below are the guidelines to all three styles.

NOTES:

1. All Shrouds must be constructed of stainless steel, aluminized steel or copper. Non-metallic materials - such as brick, stone, clay products, stucco, etc., may also be used if they are 100% non-combustible, can withstand the surrounding environment (exposure to heat, cold, rain, ice, snow, UV, etc.) and are approved by the local authority having jurisdiction.
2. Sides of shrouds (all styles) may be vertical, sloped or curved if desired, as long as indicated minimum openings are maintained.
3. In all instances a minimum of 6" of chimney must extend above the base of the Flashing/Chase cover before attaching Cap.
4. Multiple smaller openings are permitted where single larger openings are shown if minimum total open area is maintained for each.
5. Given dimensions are for a single chimney system only. Combine the required open area for each chimney system to get the minimum required total for multiple systems.

Mailbox Style Shroud

Dia	Cap Style/Dome OD	H (in.) Minimum	W (in.) Minimum
5	CT / 10	12	11
6	CT / 12	12	13
7	CT / 14	13	15
8	CT / 16	13	17
10	CT / 20	15	21
10	EZ / 16	17	17
12	CT / 24	17	25
12	EZ / 20	19	21
14	CT / 28	18	29
14	EZ / 20	19	21
16	EZ / 24	21	25
18	EZ / 24	21	25
20	EZ / 28	26	29
22	EZ / 32	28	33
24	EZ / 32	28	33

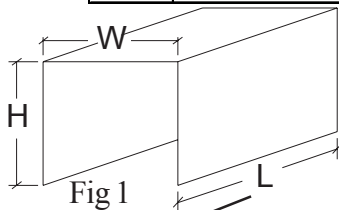

Dashed lines represent minimum dimensional design and open area (from Fig 1.) that must be present when constructing shroud. (See Fig 1)

L = (Shroud Length) Must not extend past the cap dome more than 1-1/2 times the dome diameter for sizes 5" thru 10" and 1 times the dome diameter for sizes 12" thru

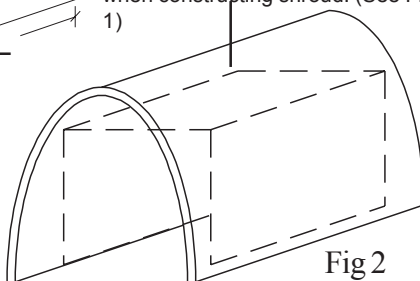

Fig 2

House Style Shroud

Dia	Cap Style/Dome OD	H (in.)	W (in.)	L (in.)	Minimum open area for single side (sq. in.) *
5	CT / 10	12	11	11	20
6	CT / 12	12	13	13	28
7	CT / 14	13	15	15	39
8	CT / 16	13	17	17	50
10	CT / 20	15	21	21	79
10	EZ / 16	17	17	17	79
12	CT / 24	17	25	25	113
12	EZ / 20	19	21	21	113
14	CT / 28	18	29	29	154
14	EZ / 20	19	21	21	154
16	EZ / 24	21	25	25	201
18	EZ / 24	21	25	25	254
20	EZ / 28	26	29	29	314
22	EZ / 32	28	33	33	380
24	EZ / 32	28	33	33	452

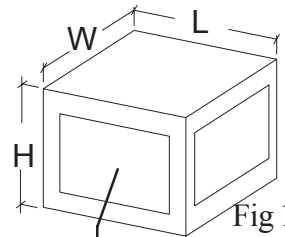

Fig 1

Dashed lines represent minimum dimensional design and open area (from Fig 1.) that must be present when constructing shroud. (See Fig 1)

Must be a minimum of open area on all four sides of shroud. Multiple openings are permitted on each side if minimum total open area is maintained for each (See Chart).

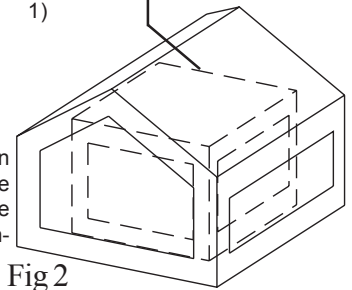

Fig 2

Pyramid Style Shroud

Dia.	Cap Style/Dome OD	W (in.) Minimum	L (in.) Minimum	a x b = Minimum open area at bottom of each side (sq. in.)
5	CT / 10	13	13	4.91
6	CT / 12	15	15	7.10
7	CT / 14	17	17	9.65
8	CT / 16	19	19	12.60
10	CT / 20	22	22	19.65
10	EZ / 16	21	21	19.65
12	CT / 24	26	26	28.30
12	EZ / 20	23	23	28.30
14	CT / 28	31	31	38.50
14	EZ / 20	25	25	38.50
16	EZ / 24	30	30	50.30
18	EZ / 24	31	31	63.65
20	EZ / 28	36	36	78.55
22	EZ / 32	37	37	95.10
24	EZ / 32	39	39	113.10

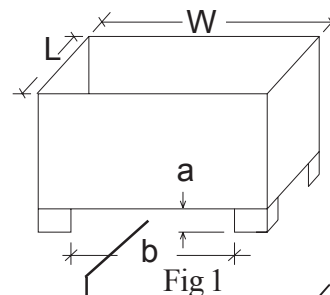

Fig 1

Dashed lines represent minimum dimensional design and open area (from Fig 1.) that must be present when constructing shroud. (See Fig 1)

Minimum open area at bottom of shroud on each side (see chart)

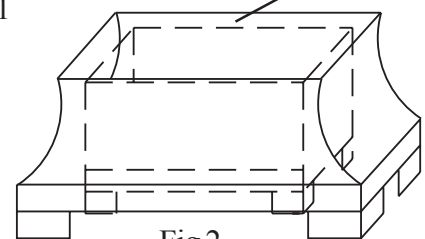

Fig 2

CLOSURE RING

Many local inspectors will allow for chimneys to be terminated with a custom design rain cap, shroud or other termination. Additional factors must be considered when installing a chimney using a termination that is not a Selkirk manufactured and listed chimney cap.

Model UTL/GTL pipe sections have exposed insulation at the ends. In most installations the Model UTL/GTL pipe is terminated with a Selkirk chimney top which protects the insulation from the elements. If any other type of termination is desired, then a Model UTL/GTL Closure Ring (Fig 1) is **required** to cover the insulation at the top of the chimney.

When installing any custom chimney termination, the weight of the termination must be taken into account when supporting the chimney. The length of pipe, equal in weight to the custom termination, must be deducted from the overall rated length (35' for an Anchor Plate and 16' for the Interior Resupport) of the supported section of chimney. This may require the addition of an Interior Resupport to a section of chimney that would have otherwise not required resupport. Additional lateral support may also be required and may be provided by using a stabilizer plate, roof brace or guy wires. Lateral support should be installed as close to the top of the chimney as possible.

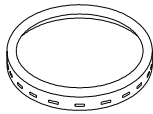

Closure Ring

CHIMNEY MAINTENANCE

1. Creosote and Soot: When wood is burned slowly, it produces tar and other organic vapors, which combine with expelled moisture to produce creosote. The creosote vapors condense in the relatively cool chimney flue of a slow-burning fire. As a result, creosote residue accumulates on the flue lining. When ignited, this creosote makes an extremely hot fire.

2. Access: Chimneys must be installed so that access is provided for inspection and cleaning.

3. When to Clean: The chimney should be inspected at least every 2 weeks during the heating season to determine if a creosote or soot build-up has occurred. Check spark arrestor screens at least every 2 to 4 weeks. If creosote or soot has accumulated and is 1/16" thick or greater it should be cleaned or replaced to reduce the risk of chimney fire.

4. How to Clean: Have your chimney cleaned by a professional chimney sweep if you have doubts about your ability to clean it. Use a plastic, wood, or steel brush. Do not use a brush that will scratch the stainless steel liner of your chimney. Scrub the spark arrestor with a wire brush. To remove the Chimney Top for cleaning, unscrew the 4, #8 x 1/2" sheet metal screws that attach the cap to the previous chimney section.

Remember to replace the Chimney Top and 4, #8 x 1/2" sheet metal screws when you are finished cleaning the chimney.

5. Chemical Cleaners: Chemical cleaners are not recommended as they may corrode the inside of the chimney. Use chemical cleaners only as a last resort, and use only those which the manufacturer specifically warrants as being noncorrosive to the chimney. Selkirk will assume no liability for damage resulting from the use of chemical cleaners.

6. In Case of Fire: If a flue fire occurs, close all appliance air inlets, and call your Fire Department. Do not use the chimney again until it has been inspected for possible damage.

7. Painting: As an option, you may coat all exterior metal parts, with the exception of the Chimney Cap, with high temperature, rust proof paint. Wash the metal with a vinegar and water solution before painting.

8. Creosote Formation: Selkirk assumes no liability for structural damage or roof contamination as the result of creosote formation. It is the owner's responsibility to comply with inspection and cleaning requirements as described in these instructions, and those of the appliance manufacturer.

CHIMNEY FIRES AND WHAT TO DO ABOUT THEM

Models GTL/UTL are not intended or designed for use as a combustion or fire chamber. It is very easy to over fire your wood burning system with kindling, scrap lumber, brush or any fast burning fuel. This can produce flames and high temperatures all the way up the chimney, and may cause chimney damage.

If you see your appliance or the smoke pipe glowing red, you are risking chimney damage, or a fire. The creosote may be burning inside the chimney. If you see flames coming out of the top of your chimney, you are either overfiring or there is a chimney fire.

If the fire in your appliance has gotten out of control, or if you suspect a chimney fire for any reason, follow these steps:

1. Alert your family and any other building occupants of the possible danger.
2. Immediately close all dampers and/or air entrance openings to your appliance and call your Fire Department.
3. After a chimney fire, when it is safe to do so, check internal locations such as the attic and under the roof and keep watching for two or three hours. There may be delayed smoldering and subsequent ignition, even if the fire inside the chimney has been controlled.
4. Do not continue to use your fireplace until it and your chimney have been thoroughly inspected. Overheating can cause metal parts to expand, buckle and crack. If you are not certain, have a qualified heating person disassemble all parts so they can be inspected and replaced.

If you need to contact Selkirk about your Chimney System, refer to the address and telephone number located at the bottom of this page.