





RS Chimney Fan for Solid Fuel Applications

USA

CAN



-  **Product Information..... Chapters 1 + 2**
-  **Mechanical Installation Chapter 3**
-  **Electrical Installation Chapter 4**
-  **Start Up and Configuration Chapter 5**
-  **Maintenance and Troubleshooting Chapter 6**

Job Name: _____

Installer: _____

Installation Date: _____

READ AND SAVE THESE INSTRUCTIONS!

ENERVEX Inc.
1685 Bluegrass Lakes Pkwy.
Alpharetta, GA 30004

P: 770.587.3238
F: 770.587.4731
T: 800.255.2923
info@chimneyfans.com
www.chimneyfans.com



1. Product Information

1.1 Function3
1.2 Shipping3
1.3 Warranty3
1.4 Package Shipment3

2. Specifications

2.1 Dimensions and Capacities4
2.2 Planning Ahead5

3. Mechanical Installation

3.1 Transport Safety Device6
3.2 Single Fan on Steel Chimney6
3.3 Single Fan on Brick Chimney7
3.4 Multiple Fans on Steel Chimney8
3.5 Multiple Fans on Brick Chimney8
3.6 Installation for High Temperatures8

4. Electrical Installation

4.1 General9
4.2 Connection and Wiring Diagram for Single Fan with FSC9
4.3 Connection and Wiring Diagram for Two Fans with FSC10
4.4 Connection and Wiring Diagram for Single Fan with EFC21110

5. Start-Up and Configuration

5.1 System Testing11
5.2 Testing Fireplace or Stove11
5.3 Testing Pizza Oven11
5.4 Operating Fireplace and Stove12
5.5 Operating Pizza Oven12

6. Maintenance & Troubleshooting

6.1 Prior to Cleaning13
6.2 Care and Cleaning13
6.3 Chimney Cleaning Intervals13

Symbol Legend:

The following terms are used throughout this manual to bring attention to the presence of potential hazards or to important information concerning the product.



Danger: Indicates an imminent hazardous situation which, if not avoided, will result in death, serious injury or substantial property damage.



Caution: Indicates an imminent hazardous situation which, if not avoided, may result in personal injury or property damage.



TO REDUCE THE RISK OF FIRE, ELECTRICAL SHOCK OR INJURY TO PERSONS, OBSERVE THE FOLLOWING:

1. Use this unit in the manner intended by the manufacturer. If you have questions, contact the manufacturer at the address or telephone number listed on the front of the manual.
2. Before servicing or cleaning the unit, switch off at service panel and lock service panel to prevent power from being switched on accidentally.
3. Installation work and electrical wiring must be done by a qualified person(s) in accordance with applicable codes and standards.
4. Follow the appliance manufacturer's guidelines and safety standards such as those published by the National Fire Protection Associations (NFPA), and the American Society for Heating, Refrigeration and Air Conditioning Engineers (ASHRAE), and the local code authorities.
5. This unit must be grounded.

How to use this manual

This installation manual does not contain any system design documentation. System design documentation is available from any authorized ENERVEX representative.

Accessories and controls are not covered by this manual. Please refer to these component's individual manuals.



1. Product Information

1.1 Function

Use The RS Chimney Fan is a chimney top mounted ventilator and fan speed control that is designed to provide large flue gas volume capacities. It is intended for use with solid fuel but can also be used for non-solid fuel provided a safety system is part of the installation (refer to the manual: “RS for Gas & Oil Applications”). The use of the RS Chimney Fan is not restricted to any type of chimney, because the fan creates a negative pressure (below atmospheric) in the chimney.

Typical uses are: Controlling the draft for a residential solid fuel fired boiler, fireplace, stove, BBQ, or pizza oven.

Function The chimney fan is designed to be able to withstand the high temperatures associated with wood burning and to minimize the creosote buildup in the chimney flue and on the chimney fan. The axial vane construction provides a self-cleaning effect. This product is developed to prevent draft problems by creating a mechanical draft in venting systems and thereby also increasing the capacity and efficiency of a venting system. Though the chimney fan is not limited to such use, it is perfect for use with fireplaces, barbecues, pizza ovens and wood stoves.

Code Compliance

Installations must conform to requirements of the authority having jurisdiction. Where required by the authority having jurisdiction, the installation must also conform to the Standard for Draft Equipment and NFPA 211.

All electrical wiring must be in accordance with the requirements of authority having jurisdiction or, in the absence of such requirements, with the National Electrical Code, NFPA70.

Listings The RS Chimney Fan is tested and listed to UL Standard 378, Standard for Draft Equipment. The fan is manufactured at an ISO9001 certified plant and bears the European CE compliance label.

1.2 Shipping

The packing list (attached to one of the packages) clearly lists all items in the shipment and each package has a label showing the contents. Check the list against all materials on the job site for completeness.

NOTE:

All single phase fans are shipped with a capacitor and junction box connected via conduit. The capacitor is located INSIDE the junction box. Please do not discard.

1.3 Warranty

ENERVEX products are warranted for a period of two (2) years following the date of invoice. Replacement or repair will be at ENERVEX’s discretion, provided factory inspection shows a defect in material or workmanship.

Complete warranty conditions are available from ENERVEX.

2. Specifications

2.1 Dimensions & Capacities

Model		RS 009	RS 012	RS 014	RS 016	
Discharge		Horizontal				
Fan Type		Axial Vane				
Motor Type		Totally enclosed, Variable speed, Class H				
Voltage	V AC	1x120				
RPM		1600				
CFM	0.0 Ps	450	950	1400	1950	
Amperage	Amps	0.5	1.2	1.4	3.9	
Motor Output	HP	1/30	1/10	1/7	1/3	
	kW	0.025	0.08	0.1	0.25	
Weight	lbs	29	37	47	61	
	kg	13	17	21	28	
Dimensions	A	in	10.2	11.5	13.1	16.0
		mm	259	292	334	407
	B x B	in	11.7	14.3	16.6	18.8
		mm	296	364	422	478
	C	in	10.8	13.5	15.5	17.4
		mm	275	344	395	441
	D	in	3.0	3.3	3.9	3.9
		mm	75	85	100	100
	E	in	9.4	11.6	13.5	15.4
		mm	238	294	342	391
	Temperature Rating	Interm.	575°F/300°C			
		Cont.	482°F/250°C			

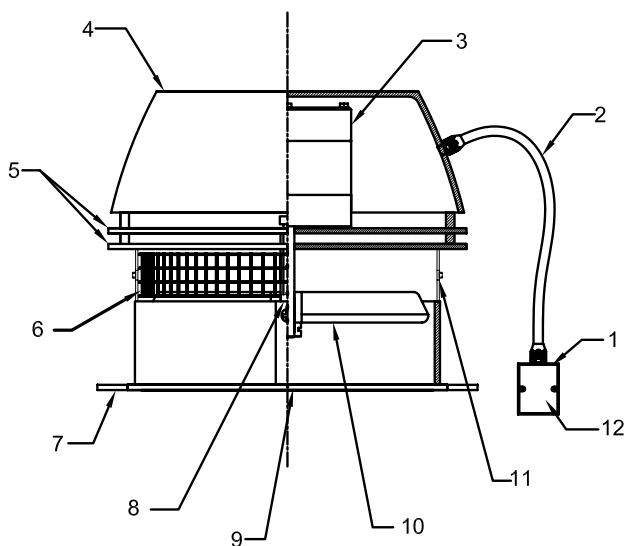
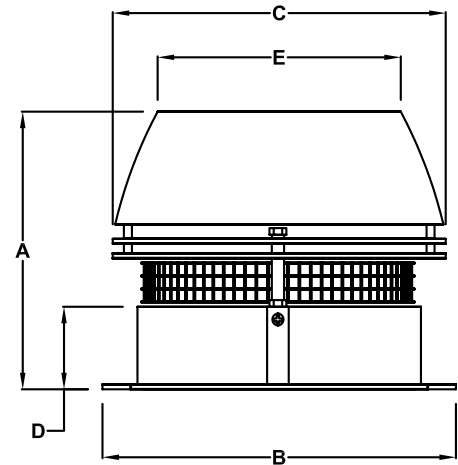

- 1 Junction Box
- 2 Conduit/cord
- 3 Motor
- 4 Motor Housing
- 5 Cooling Plates
- 6 Bird Screen
- 7 Base Plate
- 8 Locking Nut
- 9 Inlet
- 10 Axial Vane
- 11 Hinges
- 12 Capacitor (inside junction box)

2.2 Planning Ahead



1. Observe proper combustion air requirements.
2. Provide a firm support system for the chimney fan.
3. Determine the type of system involved.
4. Observe proper safety measures are taken to assure safe use of the wood burning appliances.

Combustion Air Requirements: Provisions for combustion air must be in accordance with applicable local codes.



Adequate fresh air must be provided for combustion; otherwise, improper operation and inadequate venting of deadly flue gases may result.

Support system for the chimney fan: Prior to installation of the chimney fan, it must be assured the chimney can safely carry the weight of the chimney fan.

A steel chimney should be well supported at the roof penetration point. If the chimney extends more than 20' above the roof, the chimney and the fan should be secured by wires attached on the chimney and on the roof at 2 to 3 different points.

Brick chimneys usually do not need any kind of support to carry the weight of the chimney fan.

System Type

Fireplaces and wood stoves used in residences normally operate in a relatively stable environment, where no major pressure fluctuations occur. However, speed adjustments and adjustment of air-intakes are required as the wood burns and new wood is added to the fire.

Fireplaces used in restaurants are exposed to major pressure changes. Doors open, doors close, kitchen exhaust fans pull out air, etc. Spillage can easily occur.

Wood-fired pizza ovens and barbecues are normally installed in restaurant kitchens where kitchen exhaust fans are operating. Consequently, the operator should pay attention to the fact that even with a well balanced exhaust system, it will be necessary to adjust the fan speed in order to avoid spillage.

3. Mechanical Installation

3.1 Transport Safety Device

If a transport safety device is present, remove it from the vane and make sure that the vane can revolve without hindrance.

RS 14/16: Before mounting, the transport safety device on the hinges must be removed.

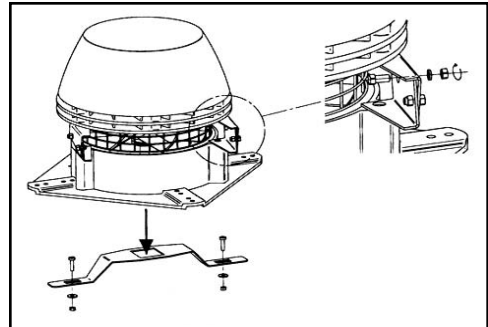

3.2 Single Fan on Steel Chimney

Step 1: Prepare fan location

If a stack cap is already installed, it must be removed. The steel chimney adapter (SCA) slides right into the chimney, where the long collar engagement ensures safe anchoring. If necessary, the adapter can be secured by means of long self-tapping stainless steel screws into the side of the collar through the chimney wall.



If the steel chimney is air cooled, a special adapter for such chimney must be used.

Measure the inside diameter of the flue and cut a corresponding hole in the center of the fiber mat. If the flue is so big that the throat in the adapter has been reduced to fit the throat of the fan, the hole in the fiber mat should correspond to the throat.

The aluminum foil on the fiber mat must face upward (against fan base).

Step 2: Preparation of fan

Locate the installation brackets in the grooves on the underside of the fan base, using the bolts and nuts supplied to secure the brackets. Note that the bolts shall be installed from the bottom side in the two inner holes.

Adjust the final position of the installation brackets ensuring that there is a small gap between the brackets and the flue wall/adapter throat. Tighten the nuts. If the brackets touch the flue wall, it may create some vibration noise.

Step 3: Attaching the fan

The chimney fan is now ready for installation on the top of the chimney. Place the fiber mat with the aluminum foil facing upwards on the top of the adapter, and place the fan on top of the mat. High temperature silicone can be applied on the side of the mat, but is not required. It can also be painted. It is not necessary to bolt the fan to the chimney.



Caution: Under conditions with extremely strong winds surrounding the top of the chimney, the chimney fan must be secured by steel wires supplied with the fan.

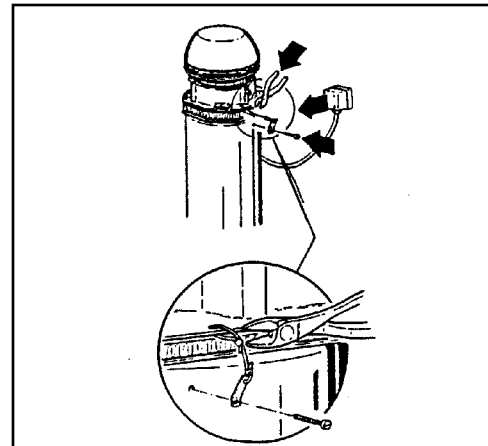
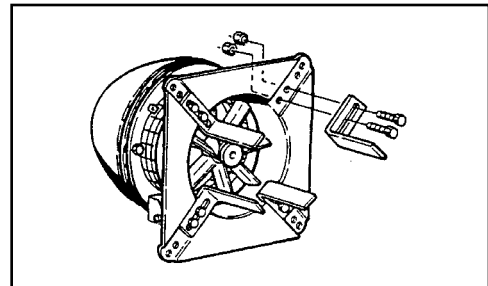
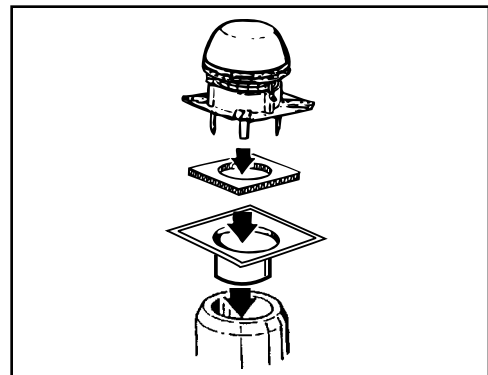

3.3 Single Fan on Brick Chimney

Step 1: Prepare fan location

The installation procedure is the same whether the flue is round or square. If a clay tile flue liner is installed, it might stick up a few inches. Cut it back so it is flush with or no more than 1/2 inch above the chimney crown.

Measure the inside diameter of the flue, cut a corresponding hole in the fiber mat leaving a minimum distance of 3/4" to any side of the fiber mat.

The aluminum foil on the fiber mat must face upwards (against fan base).

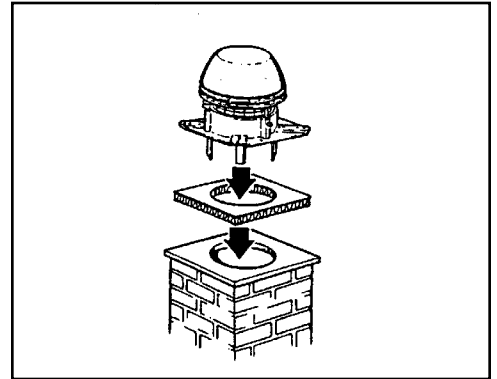

Step 2: Preparation of fan

Locate the installation brackets in the grooves on the underside of the fan base using the bolts and nuts supplied to secure the brackets. Note that the bolts shall be installed from the bottom side in the two inner holes.

Adjust the final position of the brackets ensuring that there is clearance between the brackets and the flue wall. If the brackets touch the wall, it may generate some vibration noise.

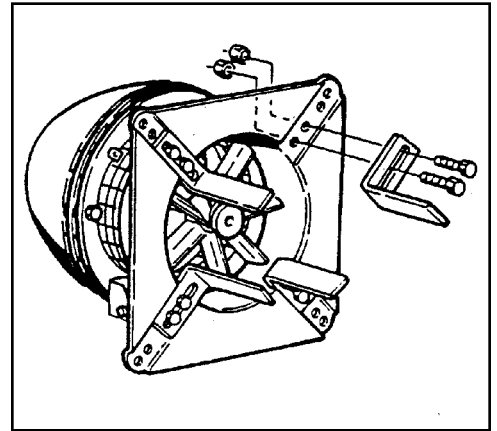

Step 3: Attaching the fan

The chimney fan is now ready for installation on the top of the chimney. Place fiber mat with the aluminum foil facing upwards on the top of the chimney, and place the fan on top of the mat. High temperature silicone can be applied on the side of the mat, but is not required. It can also be painted. It is not necessary to bolt the fan to the chimney.

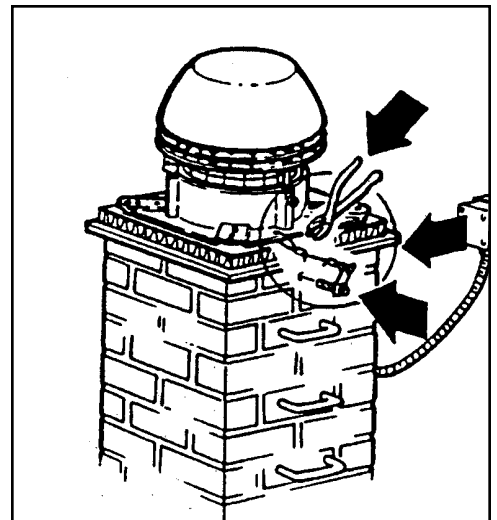

Caution: Under conditions with extremely strong winds surrounding the top of the chimney, the chimney fan must be secured by steel wires supplied with the fan.

3.4 Multiple Fans on Steel Chimney

If two or more chimney fans are required to create sufficient draft, installation procedures are the same as for single fan installation on a steel chimney. The only difference is that the fans are sitting next to each other on the top of the chimney. A special adapter plate is required (14 GA or thicker).

When installing multiple fans, it is extremely important that the fans are of the same model and size, and they must be controlled in tandem by one (1) motor speed control.

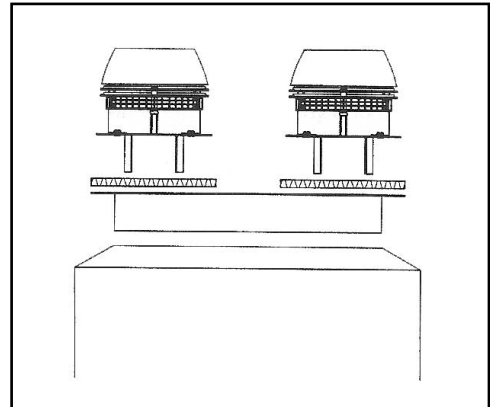

3.5 Multiple Fans on a Brick Chimney - Oversized Flue

If two or more fans are required to create sufficient draft, a special adapter plate is required. The adapter plate should be made of stainless steel (14 GA or thicker), depending on the size and the fan models used.

The two holes in the plate should match the throat diameter of the fan model used and the distance from center to center should be at least equal to the fan width (dimension "B" in 1.5. Dimensional Data).

The adapter should be sealed with silicone and bolted onto the top. When installing multiple fans, it is extremely important that the fans are of the same model and size, and they must be controlled in tandem by one (1) motor speed control.

A similar approach should be taken if the flue size exceeds the fan base dimensions. The adapter plate should be sized so it covers the flue and secured. A hole should be cut in the center of the plate and the fan mounted centered over the hole.

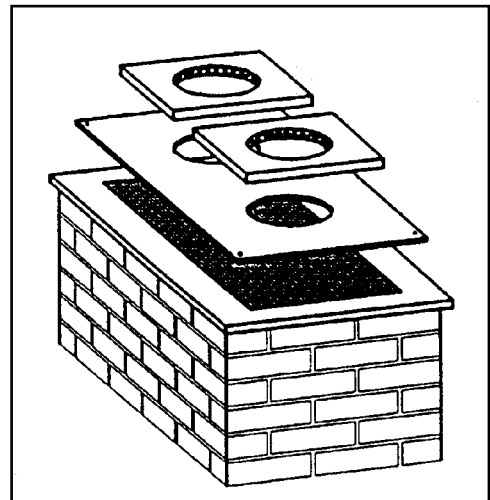

3.6 Installation for High Temperatures

If the fan is used for applications where the flue gas temperatures exceed 400°F at the flue exit, and does not exceed 650°F, dilution bolts must be used.

Dilution bolts will cause cool air to dilute the warm flue gas, by lifting the fan and leaving space so the cool air can get in under the fan base.

The dilution bolts should be installed in the outer holes in the fan base.

The dilution bolts are adjustable and should be adjusted so the flue gas temperature does not exceed 400°F when discharged through the fan. When using dilution bolts the fan's actual capacity is reduced and a stronger model may be required. The fiber mat is not required when using dilution bolts.

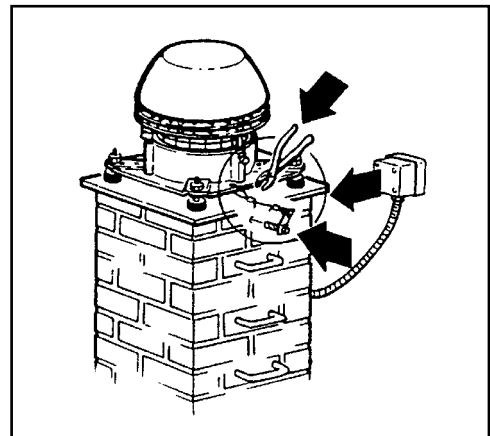

4. Electrical Installation

4.1 General



Danger: Turn off electrical power before servicing. Contact with live electric components can cause shock or death.

All electrical wiring must be in accordance with requirements of authority having jurisdiction or, in absence of such requirements, with National Electrical Code NFPA 70 — latest edition. If an external electrical source is utilized, system must be electrically grounded in accordance with requirements of the authority having jurisdiction or, in the absence of such requirements, with the National Electrical Code NFPA 70 — latest edition.

Power requirements for the system depends on the fan size. Electrical requirements are:

RS 9	1 x 120 V/60Hz	0.4 Amps
RS 12	1 x 120 V/60Hz	1.2 Amps
RS 14	1 x 120 V/60Hz	1.4 Amps
RS 16	1 x 120 V/60Hz	3.9 Amps

The chimney fans have a split capacitor motor with infinitely variable speed.

The fan speed control supplied is rated 1x120V/60 Hz and 5 Amps. It has an adjustable low voltage set point of min. 65 V +/- 5 V.



Notice: If any of the original wire supplied with the system must be replaced, use similar wire of the same temperature rating. Otherwise, insulation may melt or degrade, exposing bare wire.

4.2 Connection and Wiring Diagram for Single Fan with Fan Speed Control

The wiring diagram below shows the wiring of the chimney fan and how it is connected to the fan speed control.

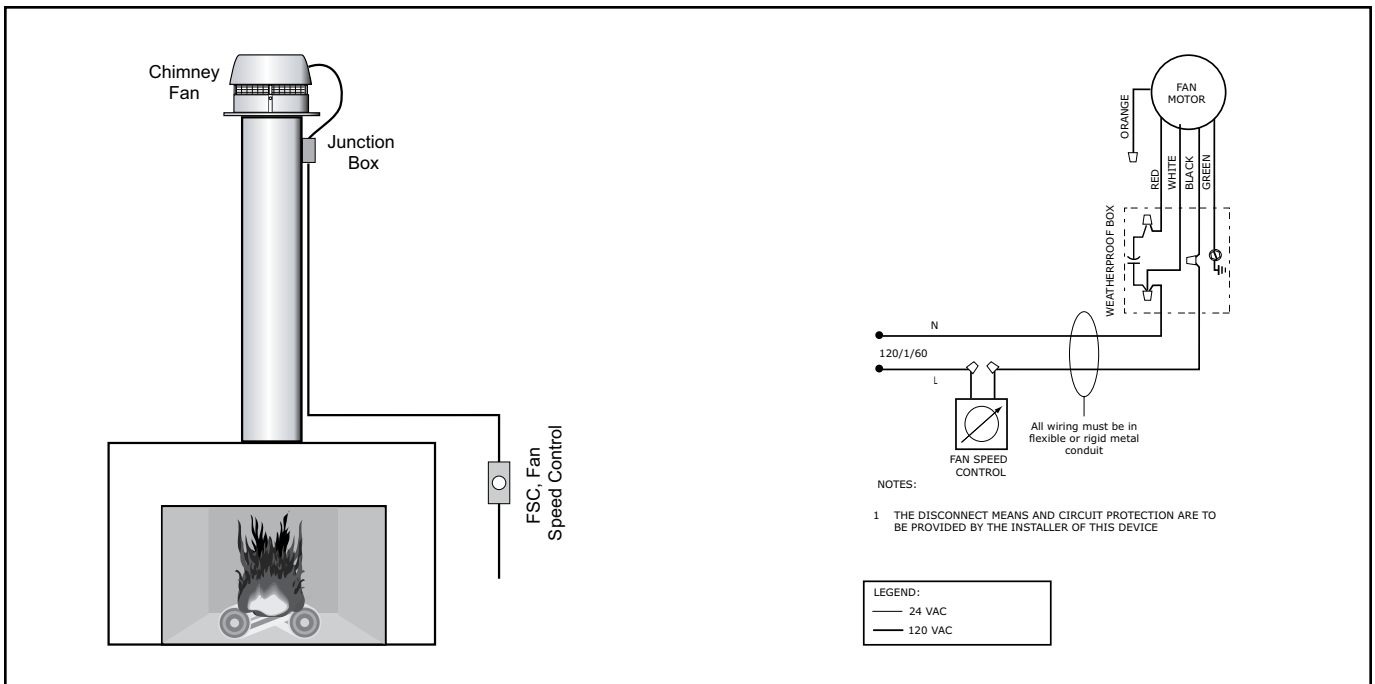

4.3 Connection and Wiring Diagram for Two Fans with Fan Speed Control

The diagrams below show the wiring of two chimney fans and how they are connected to the fan speed control.

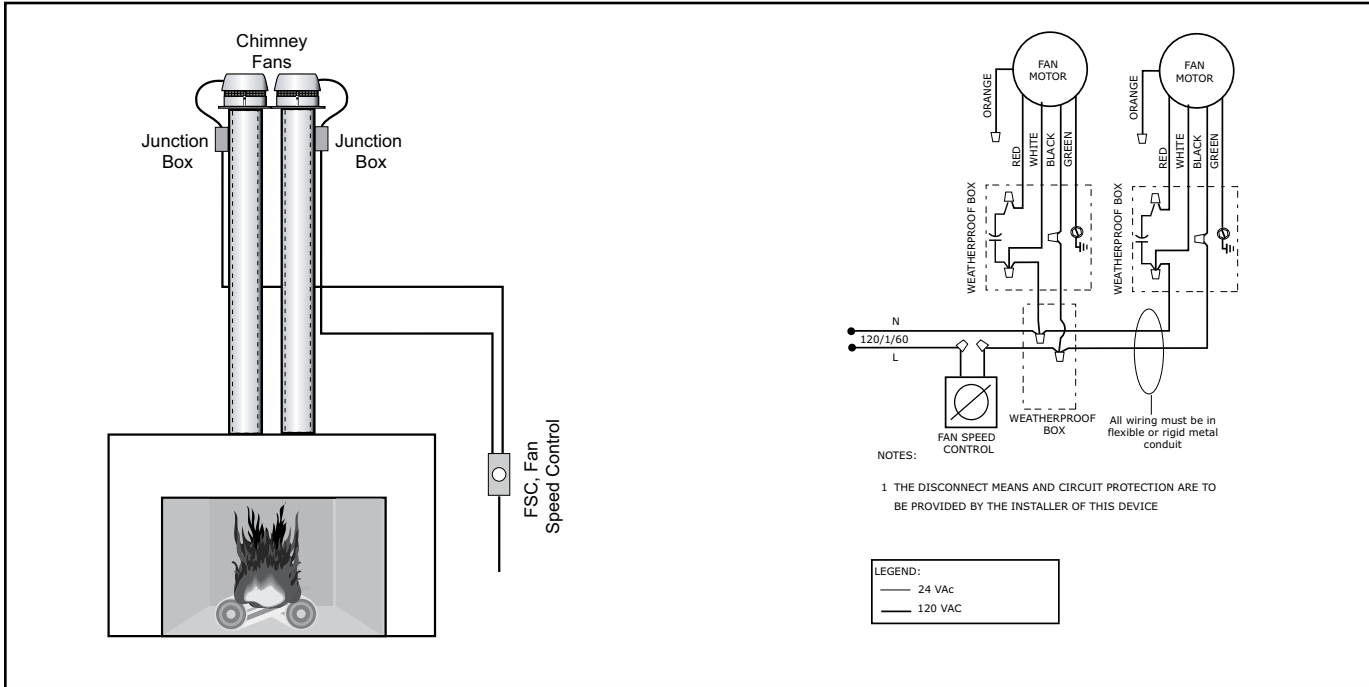

4.4 Connection and Wiring Diagram for Single Fan with EFC211

The diagrams below show the wiring of a single chimney fan when used in conjunction with an EFC 211 Control

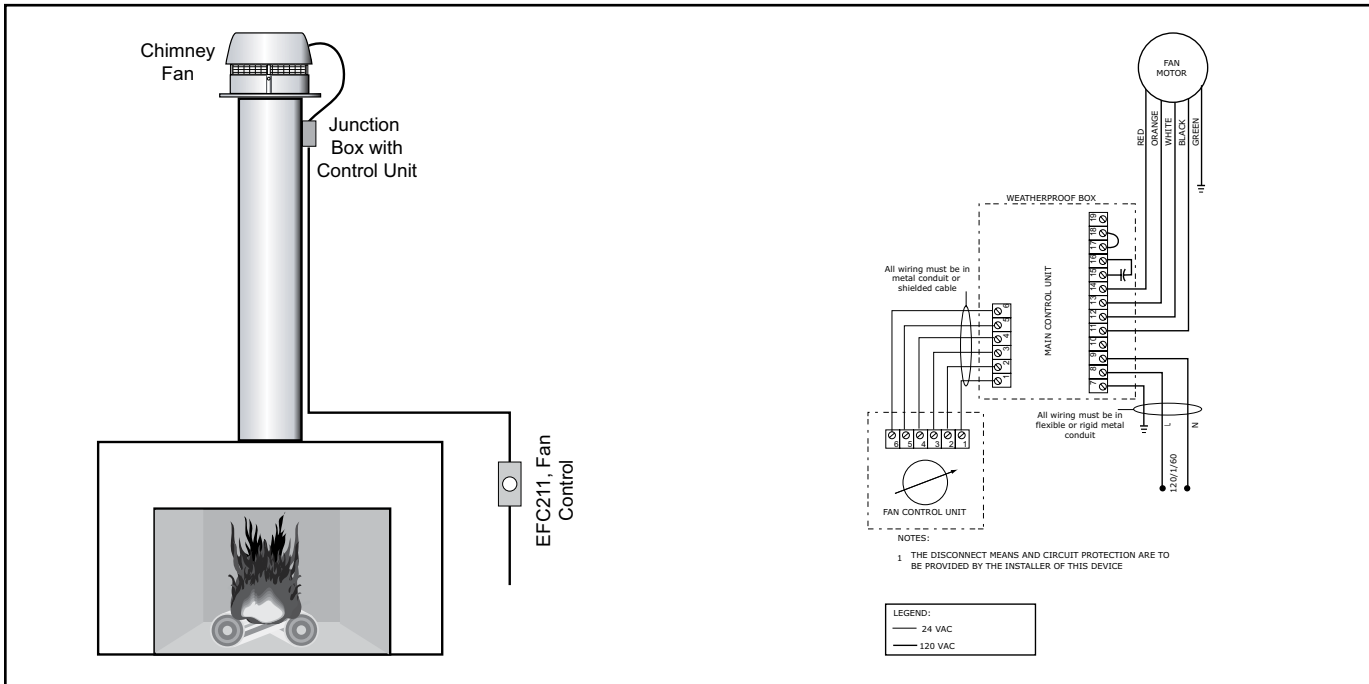



5. Start-Up and Configuration

5.1 System testing

Before any adjustments are made to the system, follow these procedures:

Turn the chimney fan ON and make sure that it is operating. Increase and decrease the speed of the fan by adjusting the fan speed control to make sure it is operating properly.



Danger: Check heating appliances (water heater, furnace, etc.) for proper operation while the chimney fan is operating. Make sure no flue gases are spilling out as this can lead to carbon monoxide poisoning.

5.2 Testing Fireplace/Stove

Place a few logs on a grate or on the floor of the fireplace or stove. Before lighting the fire, set the fan at high/full speed (on stoves, open air intake completely). Light the fire and make sure there is no spillage from the fireplace opening or from the stove's air intake (see figure).

When the fire has caught on, reduce the speed of the chimney fan to a point where it still removes the flue gases safely. Mark this setting on the fan speed control cover, as this will be the operating position/speed of the chimney fan.

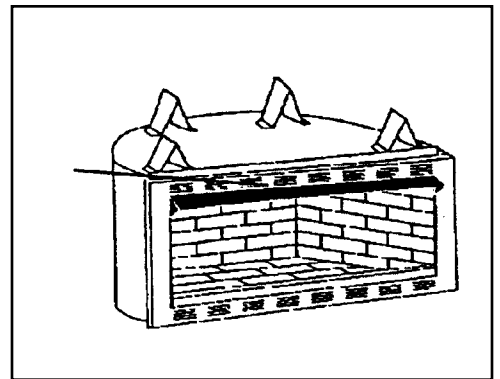

5.3 Testing Pizza Oven

Most pizza ovens consist of a dome with a front opening that can be closed with a cast iron door. Above the opening a hood connected to the flue assures smoke and odors are collected and removed safely (see figure).

Place a few logs in the back of the dome and set the fan at high/full speed. Light the fire. Turn on all exhaust fans (range hoods, etc.) and make sure there is no spillage from the hood into the room.

When the fire has caught on, reduce the speed of the chimney fan to a point where it still removes the flue gases safely. Mark this setting on the fan speed control cover, as this will be the operating position/speed of the chimney fan.

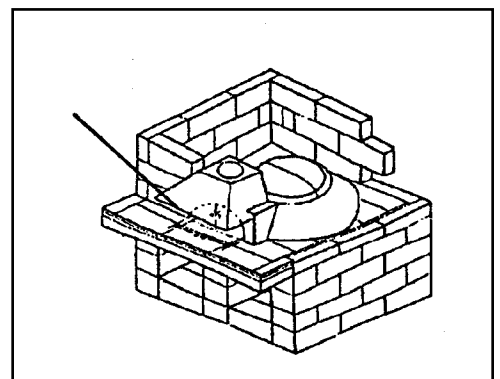

5.4 Operating Fireplace and Stove

Prior to starting a fire, set the fan at high/full speed and start the fire following the normal instructions for burning a fire in a fireplace or stove. After the fire catches on, after 3-5 minutes, reduce the speed of the chimney fan to a level where it safely removes the flue gases and a perfect flame can be maintained.

When adding wood to the fire, it may be necessary to increase the fan speed for a short period of time. Following this procedure will help conserve energy and at the same time assure a maximum heating output from the heating appliance.

5.5 Operating Pizza Oven

Prior to starting a fire, set the fan at high/full speed and start the fire following the oven manufacturer's instructions or, in the absence of such instructions, normal instructions for burning a fire in a fireplace or stove. After the fire catches on, after 3-5 minutes, reduce the speed of the chimney fan to a level where it safely removes the flue gases and a perfect flame can be maintained.

When adding wood to the fire, it may be necessary to increase the fan speed for a short period of time.



Caution: Do not over-fire the fireplace, stove or pizza oven. Small deposits of creosote could be ignited and start a small chimney fire which could cause the chimney flue to reach a dangerously high temperature.

6. Maintenance & Troubleshooting

6.1 Prior to Cleaning

Remove butterfly nut or screw from each hinge prior to cleaning.

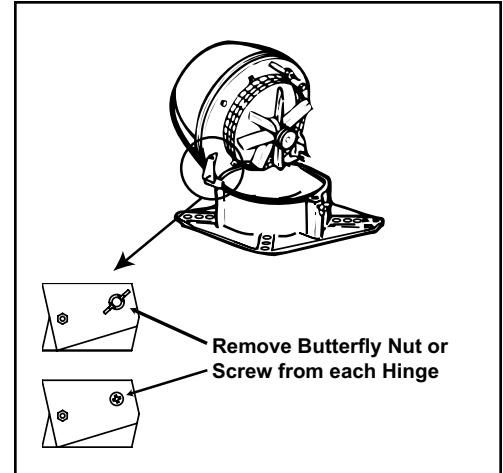

6.2 Care and cleaning

The ENERVEX Chimney Fan system is designed for prolonged use. The fan should be inspected at least once a year when the chimney is inspected. Creosote and other deposits should be removed from the fan blades and the bottom of the motor housing.

The top of the fan is hinged and can be opened in order to ease the cleaning.



Warning: Do not open the motor housing unless power to the chimney fan has been disconnected.

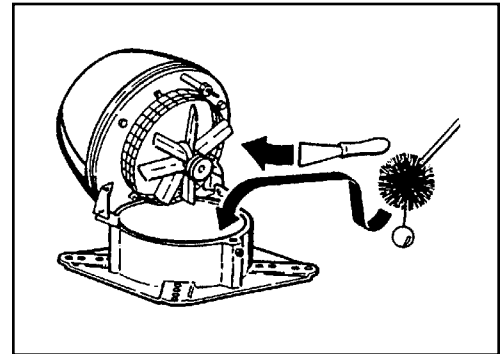

6.3 Chimney cleaning intervals

It is extremely important to keep the chimney flue clean from creosote and deposits. Creosote is the major cause of chimney fires.

Cleaning intervals depend on the use of the appliance. The more the appliance is used, the more often the chimney flue needs cleaning.

If a fireplace is used regularly (2-3 times a week), semi-annual chimney cleaning may be required. If it is used every day, shorter intervals may be required. Commercial use of wood-fired pizza ovens may require chimney cleaning every 2-3 months.

No matter how much used, a chimney flue serving wood-fired appliances should be cleaned and inspected at least once every year.

NOTE: The chimney should be cleaned by a trained professional. We recommend using a "Certified Chimney Sweep" certified by Chimney Safety Institute of America. You can find a Certified Chimney Sweep at www.csia.org or www.ncsg.org or by calling (317) 837-5362 or (317) 837-1500.

6.3 Troubleshooting

Observation	Problem	Solution
There is no power going to the fan	<ul style="list-style-type: none"> - The circuit breaker may be off - Fan speed control is off - Bad electrical connections 	<ul style="list-style-type: none"> - Check the circuit breaker - Turn fan speed control on - Check and correct problem
There is power to the fan but it is not operating	<ul style="list-style-type: none"> - Bad electrical connections - The fan speed control's low voltage setting is too low - The fan speed control is bad 	<ul style="list-style-type: none"> - Check and correct problems with connections. Pay special attention to the wiring in the junction box - Increase the setting with the plastic screw on the fan speed control's front plate - Replace the fan speed control
There is power to the fan but it hums and does not turn	<ul style="list-style-type: none"> - The motor run capacitor may be bad. - Creosote may stick 	<ul style="list-style-type: none"> - Check capacitor and replace if necessary - Clean fan
The fan seems to work fine, but there is not enough draft	<ul style="list-style-type: none"> - The fan may be undersized 	<ul style="list-style-type: none"> - Replace with a larger fan
The fan vibrates	<ul style="list-style-type: none"> - The motor shaft may be bent - The hinges may be bent 	<ul style="list-style-type: none"> - Replace motor - Straighten out hinges
There is airflow noise from the fireplace opening	<ul style="list-style-type: none"> - The flue is undersized. - The fan is oversized and running too fast 	<ul style="list-style-type: none"> - There is not much to do about it. Try to reduce the fireplace opening - Reduce the fan speed
Mechanical noise can be heard	<ul style="list-style-type: none"> - Foreign matter may be stuck - Motor bearings may be worn out 	<ul style="list-style-type: none"> - Remove matters - Replace bearings

